

User Manual

V. 20110517-AC24V



IR High Speed Dome Camera

Please keep this user manual carefully to make the installation well

Special Preset Point Application

No.94 preset point: High speed dome camera resetting function (to factory default setup);
No.95 preset point: OSD menu function;
No.96 preset point: Camera module OSD menu function (if module has one OSD menu);
No.129 preset point: Auto scan left limitation;
No.130 preset point: Auto scan right limitation;
No.99 preset point: To run auto scan function;

From No.121 to 128 preset points be used for alarm setup:

No. 121 preset point: Alarm 1 turn on/off;
No.122 preset point: Alarm 2 turn on/off;
No.123 preset point: Alarm 3 turn on/off;
No.124 preset point: Alarm 4 turn on/off;
No.125 preset point: Alarm 5 turn on/off;
No.126 preset point: Alarm 6 turn on/off;
No.127 preset point: Alarm 7 turn on/off;
No.128 preset point: Alarm 8 turn on/off;

No. 131 to No.139 preset point be used to run pattern 1 to pattern 9;

No. 141 to No.148 preset point be used to run swing 1 to swing 8;

No.151 to No.159 preset point be used to run group 1 to group 9;

No.161 and No.162 preset point be used to establish No. 1 pattern and No. 2 pattern;

From No.171 to No.177 be used for IR light adjustment:

No.171 preset point: IR sensor be adjusted to factory default setup;
No.172 preset point: Top limitation increased (at night, IR light work later);
No.173 preset point: Top limitation decreased (at night, IR light work earlier);
No.174 preset point: Bottom limitation increased (at morning, IR light turn off earlier);
No.175 preset point: Bottom limitation decreased (at morning, IR light turn off later);
No. 176 preset point: The top limitation (the IR light turn on limitation);
No. 177 preset point: The bottom limitation (the IR light turn off limitation);

Contents

Chapter One: General Description of Product -----	4
Chapter Two: Specifications -----	6
2.1 The Size of IR Speed Dome Camera	
2.2 The Max. Camera Module Size which IR Speed Dome Camera Support	
2.3 Configuration of IR High Speed Dome Camera	
Chapter Three: Connection & Setup -----	10
Chapter Four: Protocol and Address Code Setting -----	10
4.1 The Disassemble Way of Transparent Dome Cover	
4.2 Camera Module Control Protocol and Address Selection:	
4.3 Protocol and Baud Rate Setup of IR High Speed Dome Camera	
4.4: Address Setup of IR High Speed Dome Camera	
4.5 Cautions before Operation	
Chapter Five: IR High Speed Dome Control by Keyboard -----	13
5.1 Control keyboard	
5.2 The connection between controller and system	
5.3 Communication protocol selection	
5.4 Camera selection	
5.5 P/T/Z control	
5.6 Setup of P/T/Z preset points	
5.7 Preset point call back	
5.8 Deletion of mistaken operation	
Chapter Six: Instruction of OSD Menu Setting -----	18
6.1 Checking before Operation	
6.2 OSD menu operation	
6.21 Major rules of menu operations	
6.22 Display instruction on screen	
6.23 Main menu	
6.231 SYSTEM INFOMRATION	
6.232 DISPLAY SETUP	
6.233 DOME SETUP	
6.234 EXREA SETUP	
6.235 ALARM SETUP	
6.24 Detailed instruction of dome setup	
6.25 Pattern	
6.26 Swing	
6.27 Group	
6.28 Schedule setup	
6.29 Other functions	
Chapter Seven: IR High Speed Dome Camera FAQ Guide -----	33
Chapter Eight: 255 Channels Address List -----	34

Chapter 1: General Instruction of Products

IR high speed dome camera is one high technology product of color camera, all direction pan/tilt, multi-function decoder, CPU processor, storage chip. This product decreases the connection of parts of system and installation. It increases the reliability of system. It extremely improves the stability of the system and fits different environments no matter indoor or outdoor...this dome has a weather-proof design, the housing adopts with die-cast aluminum material which is vandal-proof, water-proof, aging resistance, anti-acid rain, high temperature resistance and anti-erode.

Characteristics:

Camera Specifications:

AC24V input

The speed dome support different integrated camera module including SONY, SANYO, SAMSUNG, LG, CNB, HTS.....;

CCD Sensor: 1/4" CCD

Zoom: 18 times, 23times, 27 times, 30 times or 36 times optical zoom, 10 times, 12 times or 16 times digital zoom according to different product type.

High Speed Pan/Tilt Specifications:

The highest pan/tilt turning speed can up to 240°/S.

Vector driving movement technology makes the shortest moving trace of pan/tilt, so the time of pan/tilt movement is the shortest.

The image of monitor looks more natural.

With joystick control to get the slowest speed movement of pan/tilt, speed slow up to 0.05°/S.

Support preset point, trace, swing, auto scan, privacy masking, trace location...

Support up to 128 pieces preset point. The additional information of preset point include dwell time, alarm function, zone label... which can be set according to the demand from end user.

Support up to 16 pieces swing, this function can make camera to move from point to point with needed speed.

Support up to 16 pieces pattern, every trace up to 200 pieces command record.

Support up to 16 pieces group function. This function can support camera to auto turn from multi-preset points. One group can support up to 8 pieces preset point, pattern or swing.

Support up to 8 pieces privacy masking zone. (SONY camera module only)

P/T/Z Control:

It can control up to 255 pieces P/T/Z camera through Rs485 bus. Pelco-D protocol or Pelco-P protocol is selectable.

OSD Screen Menu Function:

The P/T/Z camera's working condition can be shown on screen; the P/T/Z setup can be done through OSD menu.

The camera series number, pan/tilt angel, alarm input/output, preset information all can be shown on screen as demanded.

Alarm Input/Output Function:

Support up to 8 pieces alarm input and 4 pieces relay output, support more selection as your demand.

If any alarm detectors be activated, the P/T/Z camera can turn to this preset point. At the

same time, one signal be sent out from relay to turn on acousto-optic alarm equipment.

Easy Installation and Operation:

The product designs meet all demand for outdoor application, built-in heater and fan, Weather-proof design totally meets the National Ip66 standard.

Chapter 2: Specifications

2.1 The Size of IR Speed Dome Camera

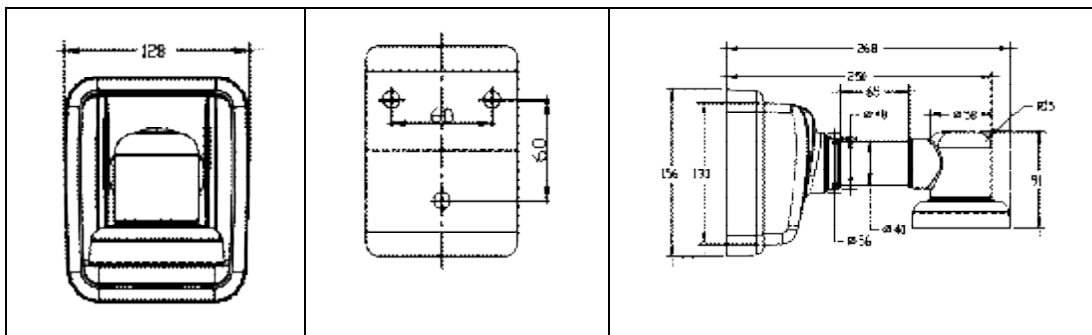

2.2 The Max. Camera Module Size Which IR Speed Dome Camera Support:

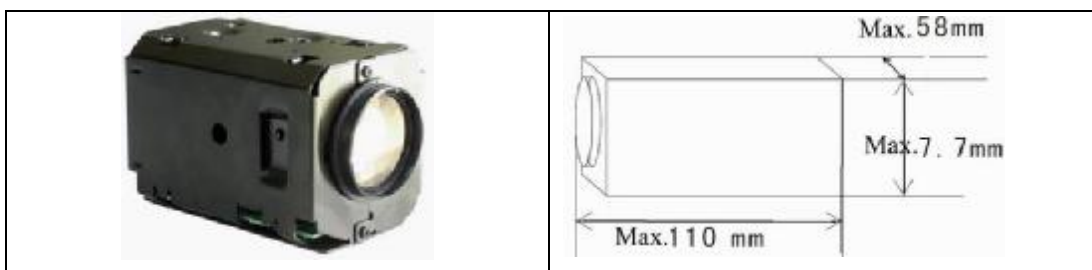

2.31 Configuration of high speed dome camera (22X , 27X 580TVL)

Camera & Specifications			
Camera	CCD	1/4" High Sensitivity SONY CCD	
	Resolution	Color:580TVL ; B/W:650TVL	
	Optical Zoom	22 times	27 times
		f=3.6-79.2mm	f=3.9-97.2mm
		F=1.6	
	IR filter	Double IR filter	
	Mini. Illumination	Color: 1 Lux; B/W:0.001 Lux(128FLD, 30IRE)	
	S/N Rate	≥50 dB	
	White Balance	Auto/Indoor/Outdoor/Manuel control	
	Black Light Compensation	Internal On/Off (AGC off)	
	Electronic Shutter	1/50~1/10000 Sec	
Pan/Tilt	Turning	Scope	Pan 360°; Tilt 90°
		Preset	360°/Sec
		Manual	0.025°~120°/Sec
		Swing Speed	200°/Sec
		Auto Scan	15°/Sec~60°/Sec
	Preset Quantity	128	
	Pattern	16 2Patterns, 200 commands every one	
	Swing	8 Pieces	
	Group	32 Groups and each with 16 actions	
	Protocol	Pelco-D; Pelco-P; VC; WORLD	
	OSD	Support camera module setup and speed pan/tilt setup	
Programmable OSD for Pan/Tilt, Zoom camera, Swing, Pattern, Group, Schedule... Functions.			
Fan/Heater	Built-in auto controller heater and fan		
Others	Temperature	-35°C~50°C	
	Moisture	<95%	
	Power Supply	AC24V	
	Consumption	20W	
	Heater Consumption	10W	

2.32 Configuration of high speed dome camera (18X, 26X, 36X)

Camera & Specifications					
Camera	CCD		1/4" SONY CCD		
	Resolution		480TVL	480TVL	540TVL
	Optical Zoom		18 Times	26 Times	36 Times
			f = 4.1-37.8mm	f = 3.5-91mm	f=3.4-122.4mm
			F=1.4-3.0	F=1.6-3.8	F=1.6-4.5
	IR filter		Double IR filter		
	Mini. Illumination		Color: 0.7 Lux; B/W:0.1 Lux		
	S/N Rate		≥50 dB		
	White Balance		Auto/Indoor/Outdoor/Manuel control		
	Black Light Compensation		Internal On/Off (AGC off)		
	Electronic Shutter		1/50~1/10000 Sec		
Pan/Tilt	Turning	Scope	Pan 360°; Tilt 90°		
		Preset	360°/Sec		
		Manual	0.025°~120°/Sec		
		Swing Speed	200°/Sec		
		Auto Scan	15°/Sec~60°/Sec		
	Preset Quantity		128		
	Pattern		16 2Patterns, 200 commands every one		
	Swing		8 Pieces		
	Group		32 Groups and each with 16 actions		
	Protocol		Pelco-D; Pelco-P; VC; WORLD		
	OSD		Support camera module setup and speed pan/tilt setup		
			Programmable OSD for Pan/Tilt, Zoom camera, Swing, Pattern, Group, Schedule... Functions.		
	Fan/Heater		Built-in auto controller heater and fan		
Others	Temperature		-35°C~50°C		
	Moisture		<95%		
	Power Supply		AC24V		
	Consumption		20W		
	Heater Consumption		10W		

2.33 Specifications of high speed dome camera (22X economic type)

Camera & Specifications			
Camera	Sensor	1/4" IT Exview HAD CCD SONY	
	Resolution	480 lines (color)	
	S/N	>48db	
	Zoom Ratio	22 times optical zoom;	
	Focal Length	F1.6; f=3.6~79.2mm	
	Min. Illumination	0.1Lux	
	Image Freeze	No	
	Day/Night	Yes	
	Focus	Auto/Manual	
	Iris	Auto	
	White Balance	Auto	
Pan/Tilt	Turning	Scope	Pan 360°; Tilt 90°
		Preset	360°/Sec
		Manual	0.025°~120°/Sec
		Swing Speed	200°/Sec
		Auto Scan	15°/Sec~60°/Sec
	Preset Quantity	128	
	Pattern	16 2Patterns, 200 commands every one	
	Swing	8 Pieces	
	Group	32 Groups and each with 16 actions	
	Protocol	Pelco-D; Pelco-P; VC; WORLD	
	OSD	Support camera module setup and speed pan/tilt setup	
Programmable OSD for Pan/Tilt, Zoom camera, Swing, Pattern, Group, Schedule... Functions.			
Fan/Heater	Built-in auto controller heater and fan		
Others	Temperature	-35°C~50°C	
	Moisture	<95%	
	Power Supply	AC24V	
	Consumption	20W	
	Heater Consumption	10W	

Chapter 3: Connection & Setup



There are three connection port, PSU, RS485 and video input. Do not connect power to RS485 port, or the RS485 chip will be damaged

Chapter 4: Protocol & Address Code Setting

4.1: The Disassemble Way of Transparent Dome Cover:

Before installation, please check the Communication Protocol, Baud Rate and Address Code of the control main machine in the system. There are two groups dip switch which be used to set camera module type, protocol, baud rate and address of dome camera. Please set the dip switch consistent with system.

u The Disassemble Way of Transparent Dome:



There are 4 pieces screws to fix the transparent dome with IR dome camera together, please use screw driver to drive off them. The transparent semi-sphere dome is easy be broken, be carefully.

4.2 Camera Module Control Protocol and Address Selection:



After open the transparent dome, you can see there are two dip switches which be used to select different camera module control protocol and address. The 6 bits dip switch is prepared for camera module control protocol selection, the 8 bits dip switch is designed for 255 pieces PTZ camera address.

The followed is detailed instruction of the 6 bit dip switch:

1		SONY480	17		SDM-271
2		SONY980	18		SDM-231
3		SONY1000	19		SCM-2231
4		SONY1010	20		SCM-2371
5		CNB-PNT200L	21		MD-600
6		CNB-VP800	22		MD-400
7		CNB-M1560 (M2263)	23		MD-800
8		CNB-SS803	24		VK-S858N
9		LVC-371 (LG)	25		Prepared for update
10		LG-SS823D	26		YN02
11		Gc755	27		TT-V230NP
12		D2830/X2030	28		Prepared for update
13		LM-923	29		Akance
14		Prepared for update	30		Prepared for update
15		SAG6242H	31		Sunnell
16		Prepared for update	32		Prepared for update

4.3: Protocol and Baud Rate Setup of IR High Speed Dome Camera

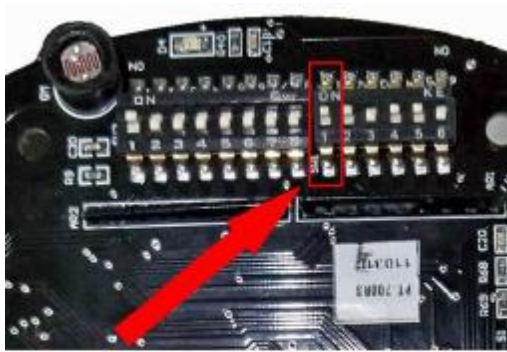

The first bit of 6 bits dip switch decide protocol and baud rate.

On=Pelco-D protocol; Baud rate: 2400bps
 Off=Pelco-P protocol; Baud rate: 9600bps

Protocol/Baud Rate		
PRO0 (Bit 1)	ON	PELCO-D, 2400bps
	OFF	PELCO-D, 9600bps

4.4: Address Setup of IR High Speed Dome Camera

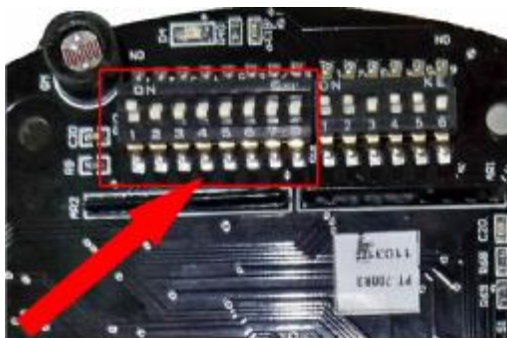

Notice

- 1.Factory default address code is 1. Pelco-D 2400bps;
- 2.If any change with setup of dip switch, please re-power IR high speed dome camera to save the change.
- 3.If SAMSUNG or HITACHI module be used, please change the module control baud rate to 9600bps, N,8,1 , or zoom function will out of control;

Before the application of high speed pan/tilt dome, the address code should be setup firstly. The address code is decided by the 10 bits dip switch on PCB which adopted with 8421 code. Support up to 1024 pieces addresses. ON is respected by Number 1. OFF is respected by Number 0. Please check the attached address list at the back of manual for the detailed setting way (Refer to Address code DIP diagram).

The Method of Address Code Setup

Serial NO.	1	2	3	4	5	6	7	8	9	10
Address Code	1	2	4	8	16	32	64	128	256	512

Dip switch has defined address number for each bit, as above diagram: No.1 stands for 1st address No., No.2 stands for 2nd address No., No. 3 stands for 4th address No., and No. 4 stands for 8th address No....., how many channels you would like to set, just dip the relevant serial number to "on". You can add existing address bits to get what you can not find from the dip switch diagram.

I.e. if you want to dip the 1st address No, just dip serial No. 1 to "ON".

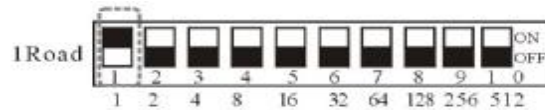

If you want No.37 address. iust dip No.1. No.4. No.32 to "ON" position.



4.5 Cautions before Operation



Before installation, the transparent semi-sphere dome should be taken off firstly, take out the sponge which be used to fix camera module inside. When you move the IR high speed dome camera or take out sponge, please do carefully. The material of transparent semi-sphere dome is acrylic which is easy be broken.



In order to avoid IR light reflection in the transparent dome to affect camera module image quality, the transparent dome be made with isolation hole by laser. Notices: the long hole is the direction which camera module on.

Chapter 5: IR High Speed Dome Control by Keyboard

All the functions of high speed dome camera can be achieved through the control by keyboard. Because the detailed operation from different company is different, if the control system is from other company, please control the dome according to the instruction from control system supplier. Some special functions of high speed dome ask special operation, please connect with the control system supplier for detailed operation way.

5.1 Control Keyboard



5.1.1 General Instruction about Keyboard

Characters:

- I One keyboard can control up to 255 pieces P/T/Z camera.
- I Up to 255 pieces preset points can be setup with PT-4340 keyboard.
- I Up to 32 pieces P/T/Z equipment, up to 16 pieces preset points operation can be controlled by one keyboard at the same time.
- I The dwell time of preset points can be setup from 1 to 60 seconds.
- I Multi-protocol support: Support Pelco-P, Pelco-D, VC protocol.
- I RS485 half-duplex control.

Specifications:

- I Input voltage : DC9V-12V.
- I Power consumption : $\leq 5W$.
- I 32 pieces nodes can be connected on RS485 bus, but the total distance won't be more than 1200m.

Notes:

The RS485 adapter has anti-surge function. Protect the RS485 communication port. When P/T/Z and controller be connected together, the RS485 adapter must be connected.



5.2 The connection between controller and system

1. The connection cable from controller is one 8-core cable. The definition of the 8 pieces core as follows :

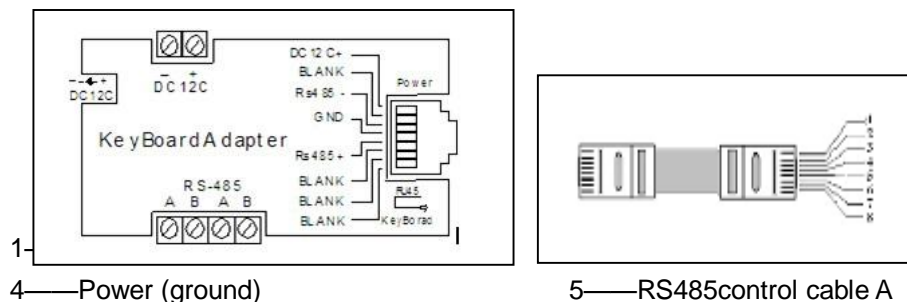

(We suggest choosing our controller with dome camera that can help you to get more function)

For the following description, control way is the same, no matter what protocol to be selected. Like Pelco-D, Pelco-P or anyone else!

The connection of adaptor

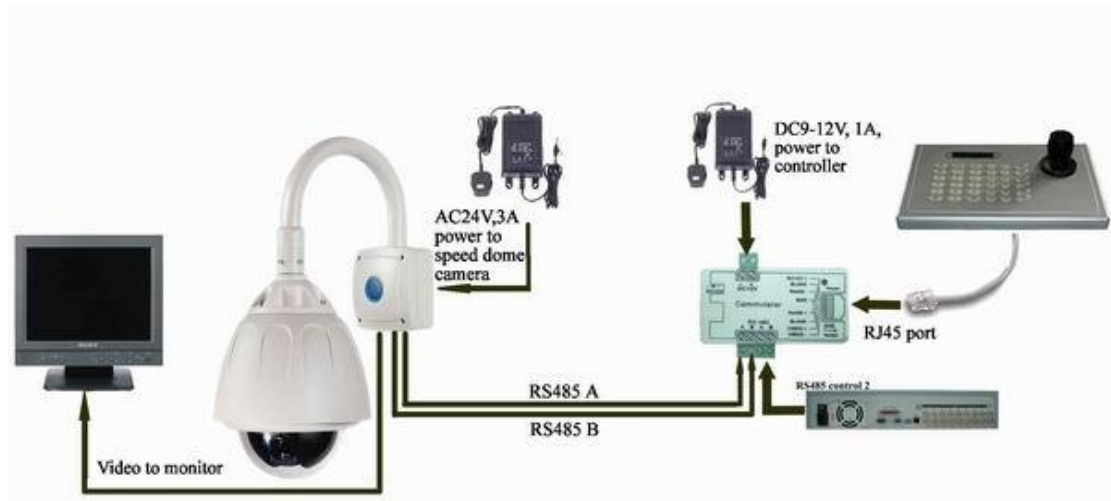

1. Connect the input power to the 12VDC port on adaptor or power port, (one port is enough, do not connect power to two ports) .Use the net cable to connect controller and adaptor.
2. Adaptor RS485 A to System RS485 A, adaptor RS485 B to System RS485 B. Total 32 pieces decoder or other equipment can be connected to RS485 bus.
3. RS485 bus selection: The bus should be shield twisted-cable. The shield layer connected to ground. The size of cable core is related to the transmission of bus cable. Long distance should select thicker cable (0.75-1mm²). For closed distance, the size of core should ≥0.2 mm².

5.3 Communication protocol selection

After connection of all together, the communication protocol selection will be show on the screen when you press" F4". The protocol definition as bellow:

Pelco-P	Pelco-P protocol	9600bps
Pelco-D	Pelco-D protocol	2400bps
HD-SC	Shanghai Security protocol	2400bps
VC	VC Protocol	9600bps
Pelco-P	Pelco-P (continuous communication)	9600bps

The above definition is the switching way for communication protocol according to the order of pressing on the "F4" key, it can help to distinguish the two Pelco-P protocols.

5.4 Camera selection

1. Selecting any camera: Just input 1—255 address number, then input CAM.
2. Selecting next camera: Input +1, then the next camera be selected.
3. Selecting last camera: Input -1, then the last camera be selected.

I.E. To select No.2 camera:

Input 2, then input CAM, the No.2 camera be selected; After No.2 camera be selected, input +1, the No.3 camera be selected; If you want to select No.1 camera after NO.2 camera be selected, just input -1, then the No.1 camera be selected;

5.5 P/T/Z control

- a. Input the camera series number which one you want to control.
- b. Input ZOOM+, ZOOM-, FOCUS+, FOCUS- or just move the joystick to control pan/tilt and lens control

I.E. Control No.2 P/T/Z camera:

Input 2 + CAM, then using joystick to move pan/tilt to the wanted position-----input ZOOM+, ZOOM-, FOCUS+, FOCUS- to control dome camera.

5.6 Setup of P/T/Z preset points

- a. Select wanted camera, then use joystick to move the camera to the appointed position.
 - b. Input F1 + 8;
 - c. Input you wanted series number for this preset point (from 1 –128);
 - d. Input PRE, then one preset point be established.

I.E. To establish No.15 preset point on No.5 camera:

Input 5 + CAM to select No.5 camera firstly, then use joystick to move camera to the wanted position. Input F1 + 8+ 15+ PRE

If you want to establish different preset points, just to change another series number, repeat the above operation.

5.7 Preset point call back

5.71 Manual control:

- a. Input the camera address number which one you want to control;
- b. Input the preset point number (1—128), the default number is 1.
- c. Input CALL, the wanted preset point be called back;

I.E. To call the No.6 preset point back on No. 3 camera:

Input **3+ CAM + 6 + CALL**, then the No.6 preset point on No.3 camera be called back.

5.72 Automatically control:

- a. Input the camera address number which one you want to control;
- b. Input the largest preset point number (2-16) which want to be automatically controlled, the default number is 8. The number of automatically controlled preset point can be different with different P/T/Z camera, but the largest automatically control number is 16.
- c. Input **RUN**;
- d. Revising the dwell time on preset point

Input the new dwell time (1—60), then input **DWL**, after that the dwell time on all preset point be changed from 1 second to 60second.

I.E. To automatically control the top 10 preset point on No.7 camera, the dwell time is 20 seconds:

Input **7 + CAM** to select camera, input **10 + RUN**, input **20+ DWL**, then the top 10 preset point be called back automatically, dwell time is 20 second.

(3) Termination of preset automatically controls:

- a. To select the camera which you want to control;
- b. Input **HOLD** or just move the joystick to stop automatically turning with this camera. Other cameras won't be affected;

I.E. To stop the automatically control on No.4 camera:

Input **4 + CAM**, then input **HOLD** or just move the joystick, the automatically preset control on No.4 camera be terminated.

5.8 Deletion of mistaken operation

Input **DEL** can clean the input item on screen. If any mistakes with input, just input **DEL** to clean.

CHAPTER 6: Speed Dome Camera Controlled by OSD Menu

6.1: Checking before operation:

Checking the cable connection carefully before camera is powered;

The camera address ID of the controller must be same of the camera address ID. The camera ID can be checked by reading DIP switch on PCB of camera.

If your controller supports multi-protocols, the protocol must be adjusted to the same as camera protocol.

The protocol changing by DIP switch will be workable after camera repowered;.

Since the operation methods are different from different suppliers. Generally the operation of controller should base on the manual from the manufacturer of controller. Some special functions of our high speed dome camera can't be operated by other manufacturer's controller. There are some special demands and operations at some times, please connect with the dealer or manufacturer which you selected controller.

Since preset 95 is used to start the OSD menu, so it can't be used as regular preset. Therefore, the description "Presets 1~128 always means excluding Preset 95 in this manual"

Self-Checking Information:



Firmware:	The edition of software;
PROTOCOL:	Communication protocol
Address:	The camera address is No.1;
TV mode:	Image standard;
CAMERA:	Module type

6.2: OSD menu operation

6.2.1: Major rules of menu operation

The menu items surrounded with () always has its sub menu.

For all menu level, to go into sub menu, press F+ key, to go up to upper menu, press FOCUS- key. If you learn by heart a rule that FOCUS+ is always similar to ENTER key and FOCUS- key is always ESC key, many other functions of these keys will be easy to

understand.

To move from item to item, use Up/Down of the joystick in the Up/Down or Left/Right.

If you want to confirm a menu item, press **FOCUS+** key.

To change a value of an item, use Up/Down of the joystick in the controller. After you change a value, press **FOCUS+** key to save it or press **FCOSU-** key to cancel it.

6.22: Display instruction on screen

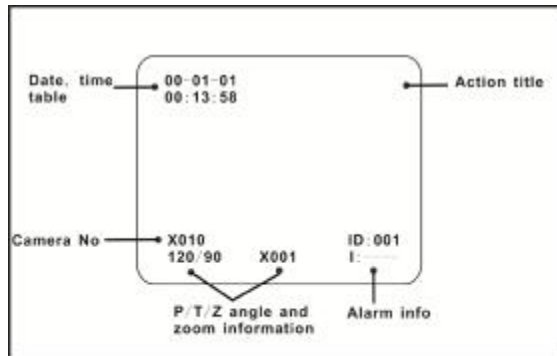

P/T/Z information:

Current Pan/Tilt angle in degree and zoom magnification.

Camera ID: Current Camera ID

Action Title: Followings are possible Action Titles and their meanings.

“SPRESET~ ”: When preset ~ is stored

“PRESET ~”: When camera reach to Preset ~

“UNDEFINED””: When undefined Preset number is called to move

“SWING ~”: When swing ~ is in action

Preset Label: The Label stored for specific Preset.

6.23: Main menu



Using No.95 preset point to come into OSD menu main menu; Image will be shown as followed:

6.231 SYSTEM INFORMATION:

 <pre>HIGH SPEED DOME ----- FIRMWARE:F3.75.006 PROTOCOL:PELCO-D 2400 ADDRESS :001 TV MODE :NTSC CAMERA :CNB 21227FRR ->BACK EXIT MENU</pre>	<p>This item be used to show the high speed dome camera system information. Including system time, date,</p>
---	--

6.232 DISPLAY SETUP:

 <pre>DISPLAY SETUP ----- ->1 .CAMERA ID ON 2 .ACTION TITLE ON 3 .PTZ INFO ON 4 .PRESET LABEL ON 5 .ALARM INFO ON 6 .SYSTEM TIME ON 7 .IR LED AUTO 8 .LIGHT SENSOR EXT BACK EXIT MENU</pre>	<p>This menu defines Enable/Disable of OSD display on Main Screen. If an item is set to be AUTO, the item is displayed only when the value of it is changed.</p>
--	--

6.233 DOME SETUP:

 <pre>DOME SETUP ----- 1 .SETUP CAMERA 2 .SETUP MOTION 3 .SETUP PRESET ->4 .SETUP SWING 5 .SETUP GROUP 6 .SETUP PATTERN 7 .SETUP PRIVACY 8 .SETUP SCHEDULE BACK EXIT MENU</pre>	<p>DOME SETUP including all main speed dome camera functions, will give detailed instruction one by one later.</p>
---	--

6.234 EXTRA SETUP

	<ol style="list-style-type: none"> 1. FACTORY RESET: This selection can be used to change the speed dome camera to factory default setup. When the setup of wing, pattern or group disordered, this function is very useful to clear all setup. 2. ADJUST TIME: Adjusting system time setup; 3. ADJUST DATE: Adjusting system date setup; 4. LNES CLEAR: This selection only useful for auto-clear series P/T/Z camera. Useless for common high speed dome camera; 5. WIPER: This select only useful for outdoor weatherproof PTZ camera which one wiper be integrated together. Useless for common high speed dome camera.
---	---

6.235 ALARM SETUP

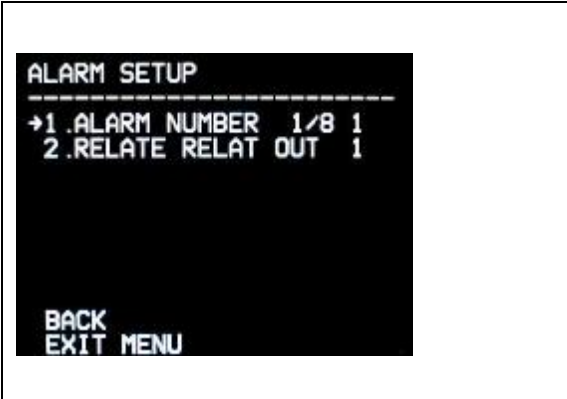
	<p>Alarm function is only used for special order which support 8 channels alarm input and one channel alarm output.</p>
---	---

6.24: Detailed instruction of dome setup:



6.241: Setup camera:

This selection mainly be used to setup camera module specifications. Different speed dome camera has different camera module inside. The setup of camera module functions can affect the image quality directly. When you setup it, be carefully. If any mistake happened, you can use the No.8 selection PRESET CAMERA on page 2 to change the camera module specifications to factory default setup.

<pre> CAMERA SETUP PAGE: 1/2 ----- ->1 .DIGITAL ZOOM ON 2 .FOCUS MODE AUTO 3 .BACK LIGHT OFF 4 .DAY/NIGHT AUTO 5 .AWB AUTO 6 .SENS UP 01 7 .WDR MODE ON NEXT PAGE BACK EXIT MENU </pre>	<ul style="list-style-type: none"> ----- ----- ----- ----- ----- ----- ----- ----- ----- ----- 	<ul style="list-style-type: none"> To decide the ON/OFF of digital zoom To decide the focus way of camera module. Manual control or auto control Back light compensation selection. If the back light is too light, please turn on this selection. Image will be more clear. Color and B/W changing; At night we select B/W situation. AWB: auto white balance selection; SENS UP: 8 different degrees on this selection. At night, if image isn't clear, this function can improve image quality. WDR: Wide dynamic range function
---	--	--

<pre> CAMERA SETUP PAGE: 2/2 ----- ->8 .RESET CAMERA 9 .PICTURE FLIP OFF A .PICTURE FREEZE ON B .CAMERA MOUDLE: 21Z27F 00021 UNKNOWN PREVIOUS PAGE BACK EXIT MENU </pre>	<ul style="list-style-type: none"> ----- ----- ----- ----- 	<ul style="list-style-type: none"> This selection can reset camera moduel to factory default situation. The image on screen can be flipped with this selectoin This function is useful for SONY module only. If this function be used, the image will be frozen when the speed dome camera is moving. From this selection, you can know which kind of camera module in the high speed dome camera
--	--	---

6.242: Setup motion

<pre> MOTION SETUP ----- ->1 .REBOOT ACTION OFF 2 .AUTO FLIP OFF 3 .MOTOR SPEED FAST 4 .JOG DIR NORMAL 5 .PARK SETUP 6 .PRESET SPEED 7 .ZOOM PROPOTIONAL ON 8 .PRECISION 100/100 BACK EXIT MENU </pre>	<p>The SETUP MOTION item mainly be used to setup the basic high speed dome camera movement speed and precision.</p>
--	---

No.1 REBOOT ACTION: This selection decide if the setup function be performed after re-power speed dome camera. Default setup is OFF;

No.2 AUTO FLIP: This selection decide if the high speed dome can flip by itself when the vertical movement to 90° ;

No.3 MOTOR SPEED: This selection decides the speed dome camera turning Max. turning

speed when the zoom is 1 time.

There are three selections: FAST: 0-180°/S ; NORMAL: 0-90°/S; SLOW: 0-45°/S

No.4 JOG DIR: When the high speed dome camera is controlled by joystick, this selection decides the sensitivity from joystick.

No.5 PARK SETUP: After the speed dome camera be installed, we need it to run by itself for watching. But after control by guards, they may forget to run the functions of high speed dome camera to keep moving watching. This function allows high speed dome camera to run by itself if there isn't any operation after certain time.

	<p>No.1 PARK ENABLE: This selection be used to enable park function or not.;</p> <p>No.2 PARK TIME: To setup how long time to wait if there isn't any operation with high speed dome camera, then to run the park function; The park time can be set from 1 minute to 4 hours;</p> <p>No.3 PARK RELAY: This selection decides which kind of function be performed as park function. Our high speed dome camera support preset point, swing, pattern and group function to be park function.</p> <p>P---Preset point; S---Swing; T---Pattern; G—Group;</p>
---	---

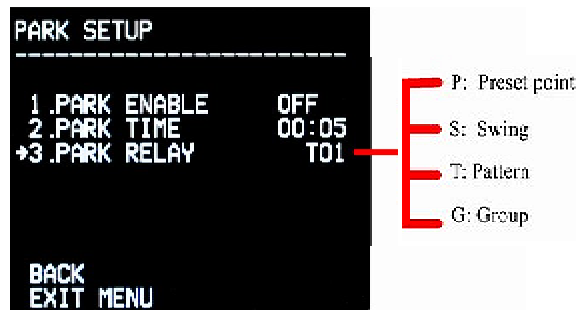

No.6 PRESET SPEED:

	<p>The highest preset point turning speed is 360°/S. But some time we don't need so far speed, if the preset point turning speed is too much fast, the preset point turning precision will be affected. So, we can adjust the preset point turning speed here. From 10% to 100% of Max. speed.</p>
---	--

No.7 ZOOM PROPOTION: When the zoom is big, the speed dome camera watching long distance objection, if the movement is fast, we can't see any. So when we watch long distance

objection, we need the speed dome camera movement slowly. This function allows the speed dome camera turning speed changing according to zoom changing.

No.8 PRECISION: This selection will affect the working voltage on motor, then affect the turning precision. We don't suggest any change with default setup.

6.243 Preset setup:

Function: Up to 127 pieces preset can be set. Besides No.95, all presets can be named as 1---128. With the combination of preset key and number key of controller, the preset point setup and call back function can be quickly operated. And modify the default preset information. (Preset label, dwell time.....)

6.2431 Setup one preset point:

Setup of Preset Point: Select camera, move camera to wanted position. Input [F1]---[8]---[preset number]---PRE

Preset Point Call Back: Input wanted preset number (default is 1), input CALL, then the preset point be called back.

Preset Deletion: Please use the preset OSD menu to delete preset, or just setup another preset with the same number to cover the old preset point;

The preset point setup also can be operated by OSD menu:

1. Using No.95 preset point to come into OSD menu, the moving cursor to No.3 DOME SETUP selection, input FOCUS+ to come into DOME SETUP menu.



2. On the DOME SETUP menu, moving cursor to the No.3 SETUP PRESET selection, input FOCUS+ to come into PRESET SETUP menu.



6.2432: Edit preset label

Label for preset point:

The cursor presents the current input position of the label letter. Upon you select the letter, the cursor will move to the left one.

Using “Up”, “Down”, ”Right”, “Left” direction of joystick. User can move cursor to select the right letter from the alphabet. Input **FOCUS+** to select the letter.

To finish the setup, move the input box to “OK” and input **FOCUS+** to save the modification.

If you want to cancel the setup of preset label, just move the input box to “Cancel” and input **FOCUS+** to confirm.



6.25: Pattern

Function: The pattern function enables us to save and play camera motions created by joystick. Support up to 200 pieces movement commands from every pattern. Totally support 16 pieces patterns;

6.251 Pattern setup:

Pattern can be created by the followed two ways:

Using the numeric **161** or **162** and **Call** to establish one Pattern:

Input [**161**---**162**], then press **CALL** more than 2 seconds to begin one establishment of pattern; Using joystick to move camera to create the trace of pattern; No.161 preset point be used to establish No.1 pattern. No.162 preset point be used to establish No.2 pattern.

The limitation of movement is 200 pieces movement commands, the command number can be shown on screen;

Input **FOCUS-** to save, **FOCUS-** to abandon;

Pattern Running: Input numeric 1 to 16 then input **SAL** to run one pattern;

Pattern Deletion: Please use OSD menu to delete pattern;

6.252 Using OSD menu to establish pattern:

Using No.161 and No.162 preset point only can setup 2 pieces pattern. If we need more pattern, we need use OSD menu to setup No.3 to No.16 14 pieces pattern.



- PATTERN SETUP: To establish one pattern for camera auto turning;
- PATTERN NUMBER 1/16: Camera support 2 pieces pattern, using this item to edit the series number of pattern; Total 16 pieces pattern.
- PROGRAM PATTERN: Using joystick to program the trace of camera, total support 200 pieces commands for one piece pattern.
- CLEAR PATTERN: To delete one pattern;
- RUN PATTERN: To run one pattern;



Using joystick to move camera to the wanted beginning position, and adjusting lens to suitable zoom times, input **FOCUS+** to begin recording, or input **FOCUS-** to abandon.

The recording supports up to 200 pieces movement commands. The total recording number be shown on screen.

The zoom changing of camera also be recorded;

At any time through recording, input **FOCUS+** to the record pattern. Input **FOCUS+** to abandon pattern recording.

6.253 Run pattern by preset point or controller:

No.131 to No.139 preset point be setup for the pattern control, details as followed:

No.131 preset point be used to run pattern 1;

No.132 preset point be used to run pattern 2;

No.133 preset point be used to run pattern 3;

.....

No.139 preset point be used to run pattern 9;

If there is one SAL key on controller or DVR control panel, please use number + SAL to run pattern as followed:

1 + SAL to run pattern 1;

2+ SAL to run pattern 2;

.....

16 + SAL to run pattern 16;

The SAL key is more powerful than preset point to control pattern function, all 16 pieces pattern can be run by number + SAL;

6.26: Swing

Function: Through the application of Swing function, the camera can move automatically between 2 preset points repeatedly.

6.261 The OSD setup of swing function:

1. Please use No.95 preset point to come into OSD menu of high speed dome camera.
2. Move cursor to the No.3 selection, then input FOCUS+ to come into the DOME SETUP selection;

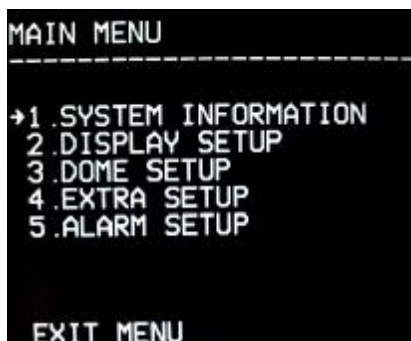

3. After come into DOME SETUP selection, you can see the followed interface:



4. The No.3 selection is the SWING SETUP selection. Using FOCUS+ key to come into the SWING SETUP interface. You will see the followed interface:



5. No.1 SWING NUMBER mean how many swing scan supported. Our 3.75 version high speed dome camera support 8 pieces swing. But when you operation, you can see No. 9 swing, you needn't to use it. The No. 9 is prepared for EXTENSION SCAN which is one very special application, seldom be used.

6. No.2 1ST POSITION mean the beginning preset point of swing;

7. No.3 2ND POSITION mean the end preset point of swing;

8. No.4 SWING SPEED mean the turning speed when swing function turning. There are 3 different speed selections for end-user. 15° /S, 30° /S and 60° /S; You can move joystick to left or right direction to change it.

9. No. 5 LOOP COUNTER: It's how many times this swing function be repeated when the swing function is selected in group function;

10. DIRECTION: Swing can turning from left to right, or from right to left; The function decide it. Just move joystick to left or right direction to change selection;

11. CLEAR SWING: When one swing be setup with wrong preset point, you can use this function to delete it;

12. No. 8 RUN SWING: Begin the swing turning;

6.262 The turning of swing function by preset point

From No.141 to No.148 8 pieces preset pint be used for swing control application

No.141 to No.148 preset point be setup for the swing control, details as followed:

No.142 preset point be used to run swing 1;

No.143 preset point be used to run swing 2;

No.148 preset point be used to run swing 8;

If there is one SAL key on controller or DVR control panel, please use number + SAL to run swing as followed:

21 + SAL to run swing 1;

22+ SAL to run swing 2;

28 + SAL to run swing 8;

29 + SAL to run swing 9; (Note: No. 9 swing is special defined for other function, don't use it for swing application)

6.27: Group

Function: The group function allows running up to 5 groups of preset, swing and pattern in sequence. Every group including preset, swing, pattern, but the total function number can't more than 200 pieces. Total 32 pieces group function supported; Through the OSD menu operation, we can establish, modify, and delete groups. The dwell time which be set with swing function still workable when group function is working.

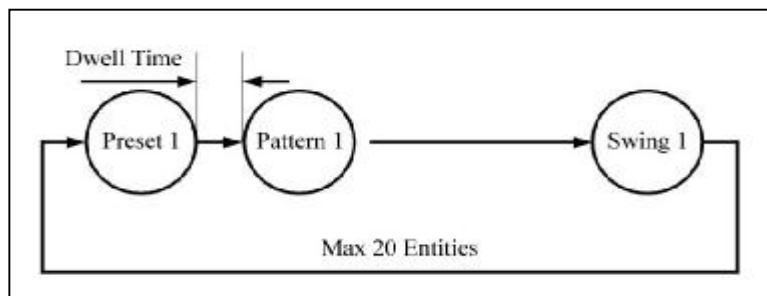

6.271: Group setup

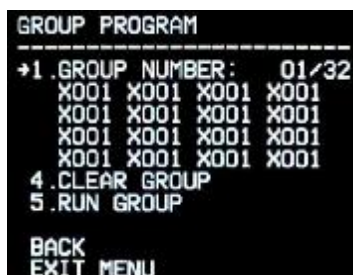

GROUP NUMBER: 1/32 the camera supports 32 pieces group function; The item be

used to set one series number of group;

Setup: "X000" means the function still not be selected; If preset be selected, it will show "P1-P64"; If swing be selected, it will show "S1-S16"; If pattern be selected, it will show "T1-T16";

CLEAR PATTERN: To cancel the group setup;

RUN GROUP: To run group;

6.272: To run group function by preset point:

Preset point 151 to 159 be used to run group function. Details as followed:

No.151 preset point be used to run group 1;

No.152 preset point be used to run group 2;

No.153 preset point be used to run group 3;

.....

No.159 preset point be used to run group 9;

If you want to run more than 9 pieces group function, please use OSD menu to run the group function.

If there is one SAL key on controller or DVR control panel, please use number + SAL to run group as followed:

31 + SAL to run group 1;

32+ SAL to run group 2;

.....

62 + SAL to run group 32;

The SAL key is more powerful than preset point to control pattern function, all 32 pieces group can be run by number + SAL;

6.28: Schedule setup

Input 95 + CALL Please OSD Menu to come into DOME SETUP, input FOCUS+ to come into DOME SETUP menu, then move cursor to No.8 SETUP SCHEDULE selection, input FOCUS+ to come into SCHEDULE PROGRAM menu.



SET ACTION: X000

“X000” means the action which still not be selected; If the preset be selected, it will show “P1~P64”; If swing be selected, it will show “S1~S16”; If pattern be selected, it will show “T1~T16”; If group be selected, will show “G1~G8”.

CLEAR ALL:

To delete all schedule.

SCHEDULE ENABLE: ON/OFF This item be used to enable schedule to work or not.

6.29: Other functions

6.291 Power off information protection:

This function can get back the last automatically running action. Besides manual operation, preset, swing, trace recording, pattern all can be got back.

6.292 Park function:

With this function, camera can automatically turn to one special position to rectify mistakes which be accumulated through automatic turning. (Normally, the park position is No.1 preset point);

If the camera is not operated for a while, the camera also can turn to park position automatically. The waiting time of park position is adjustable from 1 minute to 4 hours.

This function enables to locate the camera to specific position automatically if operator does not operate the controller for a while. The Park Time can be defined as an interval from 1min. to 4 hours.

6.293 Speed dome camera re-power function:

No.94 preset point can be used to re-power high speed dome camera. Some functions need re-power high speed dome camera to save setup, but if the high speed dome camera already in stalled on high position, it's hard to cut off power, then power on again. At this time, we can use No.94 preset point, the high speed dome camera can re-power by itself.

6.294 Special preset point application list:

- No.94 preset point: High speed dome camera re-power function;
- No.95 preset point: OSD menu function;
- No.96 preset point: Camera module OSD menu function(if module has one OSD menu);
- No.92 preset point: Auto scan left limitation;
- No.93 preset point: Auto scan right limitation;
- No.99 preset point: To run auto scan function;
- No. 131 to No.139 preset point be used to run pattern 1 to pattern 9;
- No. 141 to No.148 preset point be used to run swing 1 to swing 8;
- No.151 to No.159 preset point be used to run group 1 to group 9;
- No.161 and No.162 preset point be used to establish No. 1 pattern and No. 2 pattern;

Checking the cable connection carefully before camera is powered;

The camera address ID of the controller must be same of the camera address ID. The camera ID can be checked by reading DIP switch on PCB of camera.

If your controller supports multi-protocols, the protocol must be adjusted to the same as camera protocol.

The protocol changing on camera by DIP switch will come into work after camera restart.

Since the operation methods are different from different suppliers. Generally the operation of controller should base on the manual from the manufacturer of controller. Some special functions of our high speed dome camera can't be operated by other manufacturer's controller. There are some special demands and operations at some times, please connect with the dealer or manufacturer which you selected controller.

Since preset 95 is used to start the OSD menu, so it can't be used as regular preset. Therefore, the description "Presets 1~128 always means excluding Preset 95 in this manual"

Self-Checking Information:



Firmware:	The edition of software;
PROTOCOL:	Communication protocol
Address:	The camera address is No.1;
TV mode:	Image standard;
CAMERA:	Module type



















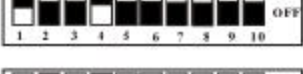





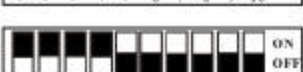
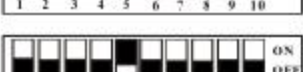





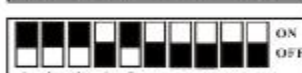
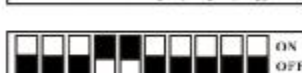

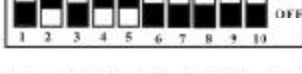





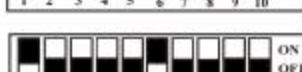

Chapter 7: IR High Speed Dome Camera FAQ Guide

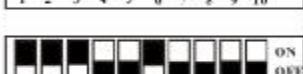
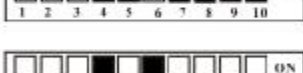
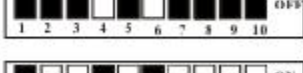
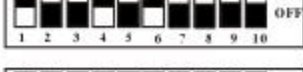
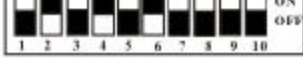
Defect	Cause	Solution
No action, image, light when connect power.	Cable connection wrong	Reconnect
	Power damage	Change
	Power connection unlinked	Fix
Self-check have the image but not control the indicating lamp not to flash	Dome Address code , Baud rate set wrong Communication protocol or Baud rate do not match	Establishes Address and Baud rate of the dome Modify
	The RS485 line reverse or open	Check Rs485 control cable connection
Self-checking cannot carry on, after having the image, the motor to sound	Mechanical breakdown	Overhaul
	Camera incline	Put straight
	Power deficiency	Select suitable power, place power near camera or thicker cable
Image fluctuation	Video Cable connection wrong	Fix
	Power deficiency	Change
	Focus at manual Mode	Set dome or run a preset
Image dimness	Housing dirty	Clean housing
	The video line connects wrong	Modify
	Video line bad contact	Fix
The self-checking movement is normal, but not have image	Camera damage	Change
	Self-check not normally	Dome again put on power
	Control line contact bad	Fix
	The main engine operation has the question	Main engine again put on power
Dome out of control or delay	Dome power deficiency	Select suitable power, place power near camera or thicker cable
	Load are excessively or communication distance is far	1. If the dome of far away control center put in matched resistance 2. Increase code divider
OSD Full Screen	The OSD pattern is whether consistent with the camera pattern	Regulate DIP switch on the dome to change pattern system

Notice: Do not attempt to service this unit yourself as opening or removing covers may expose you to dangerous voltage or other hazards. Refer all servicing to qualified service personnel.

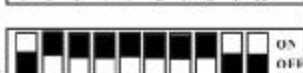
Chapter 8: 255 Channels Address List

<p>1 </p> <p>2 </p> <p>3 </p> <p>4 </p> <p>5 </p> <p>6 </p> <p>7 </p> <p>8 </p> <p>9 </p> <p>10 </p> <p>11 </p> <p>12 </p> <p>13 </p> <p>14 </p> <p>15 </p> <p>16 </p> <p>17 </p>	<p>18 </p> <p>19 </p> <p>20 </p> <p>21 </p> <p>22 </p> <p>23 </p> <p>24 </p> <p>25 </p> <p>26 </p> <p>27 </p> <p>28 </p> <p>29 </p> <p>30 </p> <p>31 </p> <p>32 </p> <p>33 </p> <p>34 </p>	<p>35 </p> <p>36 </p> <p>37 </p> <p>38 </p> <p>39 </p> <p>40 </p> <p>41 </p> <p>42 </p> <p>43 </p> <p>44 </p> <p style="text-align: center;">⋮</p> <p>251 </p> <p>252 </p> <p>253 </p> <p>254 </p> <p>255 </p>
---	---	--

RS-485 Bus Control Mode Device Connection Sketch Map

