

Par/Tilt/Zoom Position Camera System

MODEL:G50 USER INSTRUCTION

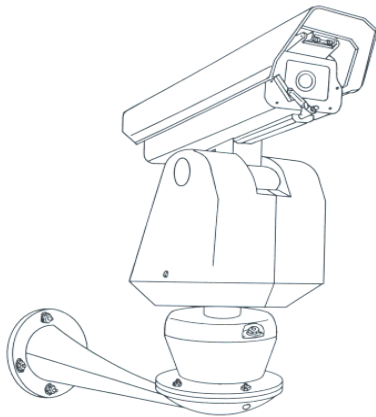

Before attempting to connect or operate this product, please read these instructions completely

Item	AU-G50-(Day/Night)
Effective pixels	752(H)× 582(V)
Scanning area	3.6mm(H)× 2.7mm(V) 1/4inch
Video output	1.0Vp-p
Horizontal resolution	470TVL
S/N Ratio	≥ 50dB
Minimum illumination	0.01Lux Mono
Iris	Auto
Focus	Auto
Focal length	F3.6-82.8mm
Zoom ratio	26 × 10 zoom
White Balance	Auto
BLC	ON/OFF
Panning range	360°endless
Pan speed	0.5° ~ 80°/sec
Tilt range	+30° ~ -85°
Tilt speed	0.5° ~ 80°/sec
Communication	RS485
Controls	Pan/Tilt; Lens; 80 preset positions
Auto pan	ON/OFF
Auto Tracking mode	4 cruising tracks
Power source	AC24V/50Hz
Operating temperature	-30°C ~ +50°C
Weight	10Kg

CONTENTS

1. PRECAUTIONS.....	
2. DESCRIPTION.....	
3. Installation.....	
4. Operation.....	
5. Trouble shooting.....	
6. Appendix: RS485.....	
7. Appendix: Cable and transmission.....	
8. Appendix : Lighting Proof.....	
9. Warranty.....	

1. PRECAUTIONS

IMPORTANT SAFEGUARDS AND WARNINGS

Prior to installation and use of this product, the following WARNINGS should be observed.

1. Installation and servicing should only be done by **qualified service and installation personnel**.
2. Installation shall be done in accordance with all local and national electrical and mechanical codes, using only approved materials.
3. Use stainless steel hardware to fasten the mount to outdoor surfaces.
4. To prevent damage from water leakage when installing a mount outdoors on a roof or wall, apply sealant around the bolt holes between the mount and mounting surfaces.
5. Unless the unit is specifically marked as a NEMA Type 3, 3R, 3S, 4, 4X, 6, or 6P system, it is designed for indoor use only and it must not be installed where it is exposed to rain and moisture.
6. The maximum load for the wall mount shall not exceed 15 kg.
7. The installation and materials used should be capable of supporting four times of the weight of the enclosure, pan and tilt unit, camera, and lens combination.
8. After replacement / repair of the unit's electrical components, resistance between line and exposed parts should be measured to make sure the exposed parts is not connected to circuitry.
9. Only use replacement parts recommended by original factory.

The product and/or manual may bear the following marks:



This symbol indicates that dangerous voltage constituting a risk of electric shock is present within this unit.



This symbol indicates that there are important operating and maintenance

instructions in the literature accompanying this unit.

2. DESCRIPTION

The Positioning P/T/Z system G50 combines a receiver, pan and tilt unit, enclosure, and Integrated Optics Package (IOP) in a single, easy-to-install system. The Integrated Optics Package contains an auto-focus camera and lens module with programmable features.

The Positioning P/T/Z system G50 is available with a power supply of 24 VAC. The system is made of lightweight aluminum and has a heater, window defroster, sun shroud, and insulation blanket.

Environment Requirement

Maximum Temp Range	-40°--+50°C
Humidity	< 90 % RH
Air Pressure	86-106K Pa
AC Power Supply	24VAC 3A 50/60HZ

3. INSTALLATION

Dimension

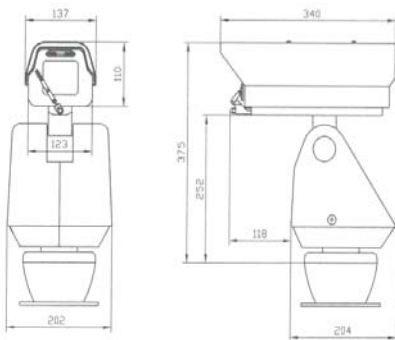

- When installing the P/T/Z system, allow for sufficient clearance between the top of the unit and overhead obstructions. This will prevent interference when the enclosure is driven to its maximum elevation of 50 degrees.

- 3.1 Remove the power supply from the base of the system by loosening the four screws and lifting the module.

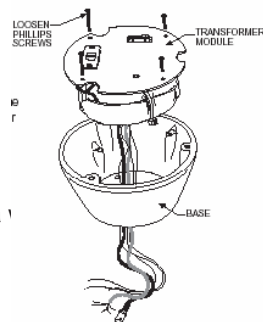

- 3.2 Attach the base of the system to a wall with four screws and washers (supplied).

- 3.3 Route the wires and cables through the center of the wall mount.

Reinstall the power supply into the base. The power supply can be positioned in the

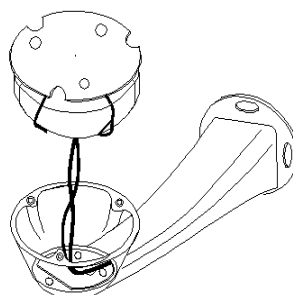

10-32

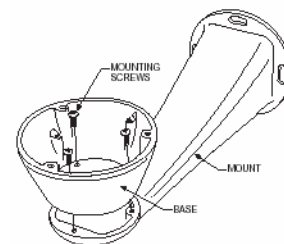

mount base in only one orientation.

- 3.4 Connect wires and cables.

a. Connect to power

The positioning P/T/Z system 3012E – The power supply's input voltage is AC24V

24VAC

brown wire	Input(AC Line)
Blue wire	AC Neutral
Green & yellow wire	Ground

b. Connect the video coaxial cable to the BNC connector.

c. Connect the wiring for a two-wire control system.

	Blue RS485+
Green wire	
	Yellow RS485-
yellow wire	

- **3.5** Install mount; refer to the installation manual supplied with the mount for instructions.
- **3.6** Plug the male G50 system connector, located on the bottom of the pan and tilt, into the female Esprit system connector located on the transformer module. Align the pan and tilt part number with the alignment label of the base and then attach the pan and tilt to the base with three 1/4-20 nuts and washers (supplied).

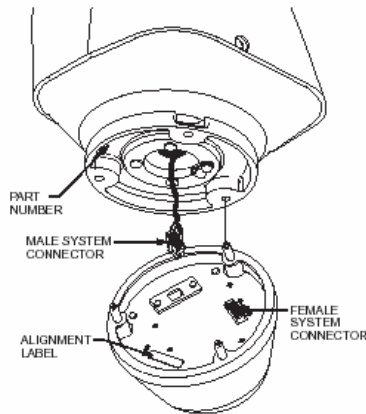

- **3.7** Set the receiver address by configuring ID address.

To set the DIP switches:

- Open the housing as following:
- For switch settings refer to the labels located on the inside lid off the housing or Tables in the Appendix.

ID Address Setting

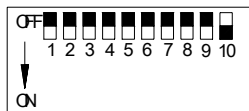

Protocol setting

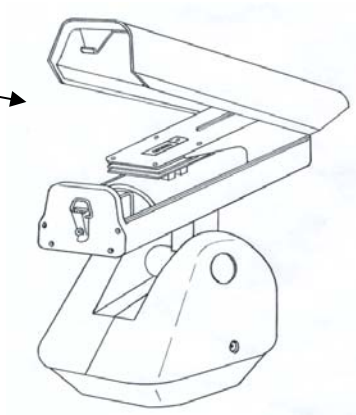
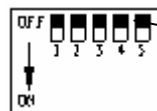

Protocol Setting

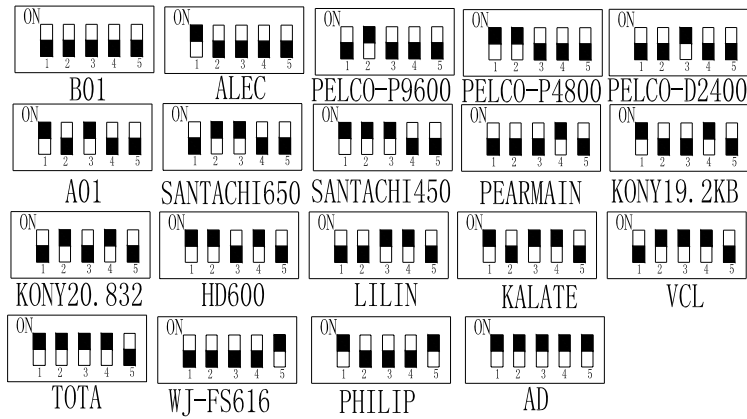

*Pelco is the trademark of pelco corporation.

*Santachi is trademark of Santachi co Ltd.

ID Address Setting

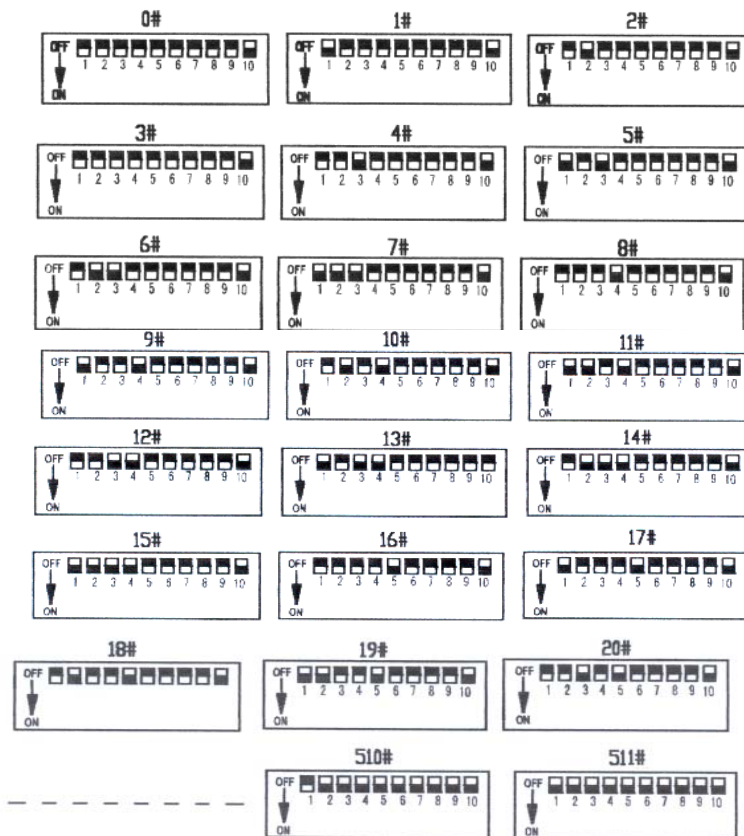

Note: The NO.10 ID code should be set to “ON” for the last camera connected to the daisy chain.

4. Operation

4.1 LED INDICATION

There are 2 LED(green , red)

Red: on----power on

Green: on---RS485 connected OK

Flashing ---the RS485 signal from controller OK



4.2. pan/tilt function

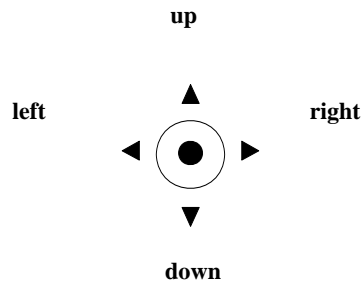

4.3.Zoom lens function

4.3.1 Zoom in and zoom out

Zoom in : to press [TELE]

Zoom out : to press [WIDE]

INDEX FOR ALL MENU

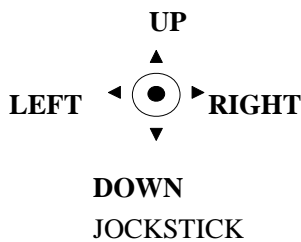

Menu display:

[CALL] +[8]+[ENTER]

menu exit:

[PRESET] +[8]+[ENTER]

move joystick up or down to select

move joystick right to confirm

move joystick left to exit

4.4 To enter Menu Display:

[call] +[8] +[ENTER]

4.5 To exit menu:

[PRESET] +[8] +[ENTER]

4.6 MENU SETTING

After powered up the speed dome will self-check. The monitor will display as following (fig6-0-0):

Dome ID	: 000
Protocol	: B01



图 6-0-0

The information will disappear after the self-check finished

Enter menu :[call]+[8]+[enter] (6-0-1) :

The monitor display:

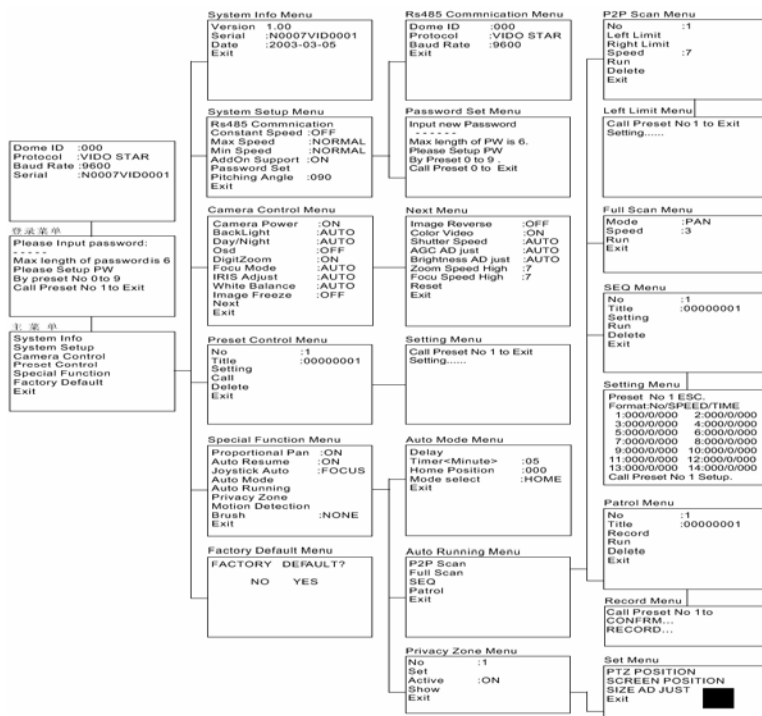
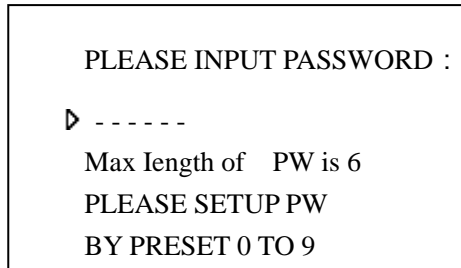

6-0-1

You must input password to enter menu

- ◆ the original password is "000000"

Move joystick to the first*, [preset]+[0]+[enter]

Means input "0"code

Move joystick to the second * repeat the last operation

After passed the password , the monitor display

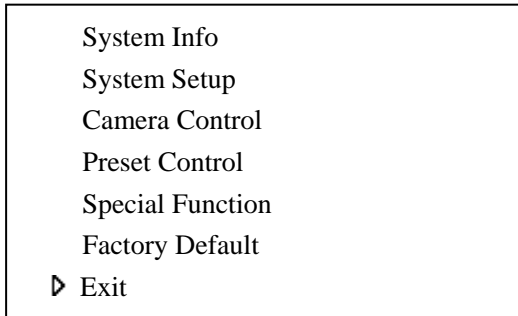

6-0-2

6 Move the cursor to System Info move joystick right ,enter the submenu as following

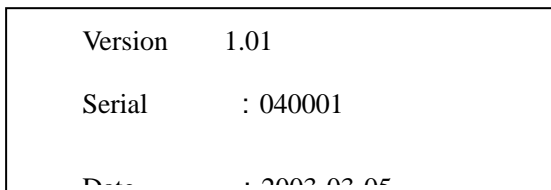

the version of dome serial number which has been labeled on each

6-1-1

This information can not be changed after factory QC passed

6.2 SYSTEM SETTING

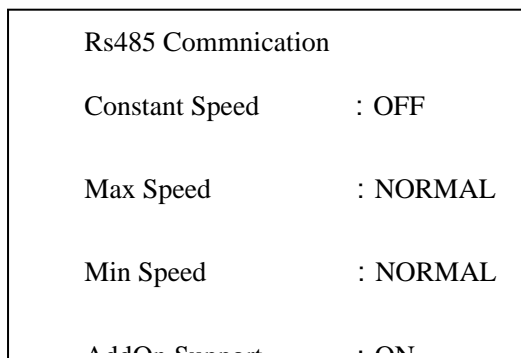

6-2-1

1. Move the cursor to RS485 communication
move the joystick right to enter
this submenu as following

Dome ID	: 001
Protocol	: B01

(6-2-2)

2. Move the cursor to constant speed
Move joystick right to enter
Move joystick up or down to select and move right to confirm
3. same setting : Max speed ,min speed addon support
when Addon Support is set “ON”
YOU CAN USE CALL ADDITIONAL “50-64”
Preset positions to set the dome camera AUX function

Auxiliary functions list of Multi Protocol speed dome series

Operation	Function
[CALL] + [50] + [ENTER]	WIPER ON
[PRESET] + [50] + [ENTER]	WIPER OFF
[PRESET] + [51] + [ENTER]	To preset NO.51 preset position means to set the start position of auto pan.
[CALL] + [51] + [ENTER]	To call NO.51 preset position means to turn on the auto pan.
[PRESET] + [52] + [ENTER]	To preset NO.52 preset position means to set the end position of auto pan.
[CALL] + [52] + [ENTER]	To call NO.52 preset position means to turn off the auto pan.
[CALL] + [53] + [ENTER]	To call NO.53 preset position means to turn on the auto track.
[PRESET] + [54] + [ENTER]	*To preset NO.54 preset position means to reset the camera.
[CALL] + [54] + [ENTER]	*To call NO.54 preset position means to soft turn on/off the power of the camera
[PRESET] + [55] + [ENTER]	To preset NO.55 preset position means to turn off the BLC function.
[CALL] + [55] + [ENTER]	To call NO.55 preset position means to turn on the BLC function.
[PRESET] + [56] + [ENTER]	*To preset NO.56 preset position means to turn off the Low illumination function.
[CALL] + [56] + [ENTER]	*To call NO.56 preset position means to turn on the Low illumination function.
[PRESET] + [57] + [ENTER]	*To preset NO.57 preset position means to turn off the screen display function.
[CALL] + [57] + [ENTER]	*To call NO.56 preset position means to turn on the screen display function.
[PRESET] + [58] + [ENTER]	To preset NO.58 preset position means to turn off the digital zoom function.

CALL + 58 + ENTER	To call NO.58 preset position means to turn on the digital zoom function.
PRESET + 59 + ENTER	To preset NO.59 preset position means to set the focus to manual mode.
CALL + 59 + ENTER	To call NO.59 preset position means to set the focus to automatic mode.
PRESET + 60 + ENTER	*To preset NO.60 preset position means to set the iris to manual mode.
CALL + 60 + ENTER	*To call NO.60 preset position means to set the iris to automatic mode.
PRESET + 61 + ENTER	*To preset NO.61 preset position means to set the white balance to manual mode.
CALL + 61 + ENTER	*To call NO.61 preset position means to set the white balance to ATW.
PRESET + 62 + ENTER	*To preset NO.62 preset position means to turn off the image freeze mode.
CALL + 62 + ENTER	*To call NO.62 preset position means to turn on the image freeze mode.
PRESET + 63 + ENTER	*To preset NO.63 preset position means to turn off the mirror picture.
CALL + 63 + ENTER	*To call NO.63 preset position means to turn on the mirror picture.
PRESET + 64 + ENTER	*To preset NO.64 preset position means to change the camera into black/white mode.
CALL + 64 + ENTER	To call NO.64 preset position means to change the camera into color mode.
PRESET + 90 + ENTER	To preset NO.90 preset position means to turn on the 'auto track function after 5 minutes' mode.
CALL + 90 + ENTER	To call NO.90 preset position means to switch off the 'auto track function after 5 minutes' mode.

Note:

1. There is only 50 preset positions (preset 1 to preset 50) available for LJD Multi Protocol speed dome.
2. Preset position and Call preset position of LJD speed dome can be done by using AU-CC-101A keyboard or other controllers.
3. There are two methods to set the Auto Tour: 1. By Call 53 and 2. By pressing [SHOT] + [ON] + [TELE] on the AU-CC-101A keyboard (the protocol has to be set at LJD B01).

The two tours are not the same. Method 1 tour can have 16 preset positions in the tour. The tour can only track from preset 1 and then preset 2.....preset 16, and again. But the PAN speed is at LJD speed 01 and dwell time is 4 seconds at each preset position in the tour.

The Method 2 tour can have 16 preset positions in its tour with varied PAN speed, dwell time (refer to AU-CC-101A manual) and different tracking sequence of preset position.

4. Move the cursor to password set move joystick to enter the sumenu



图 6-2-3

- 1) Input new code , and input the one again
- 2) New pass word OK will display after finished
- 3) [call]+[1]+[enter] to exit this submenu

6.3 camera function

Move the cursor to camera control

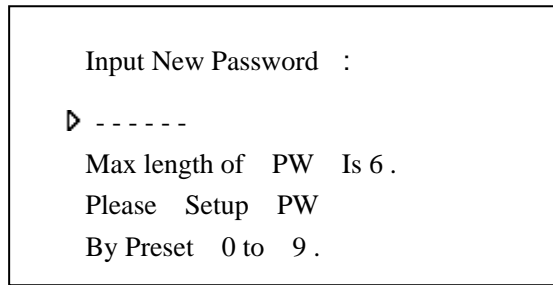
Move the joystick right to enter submenu



图 6-3-1

- ◆ BackLight : to set backlight ON/OFF
- ◆ Day/Night : to set day /night function on/off/auto
- ◆ Osd : to set OSD on/off
- ◆ DigitZoom : digital zoom on/off
- ◆ Focu Mode : near ltd infinity one push
- ◆ IRIS Adjust : auto/manual/priority
- ◆ White Balance : auto/indoor/outdoor/one push/atw/manual

- ◆ Image Freeze : on/off

- ◆ Next :

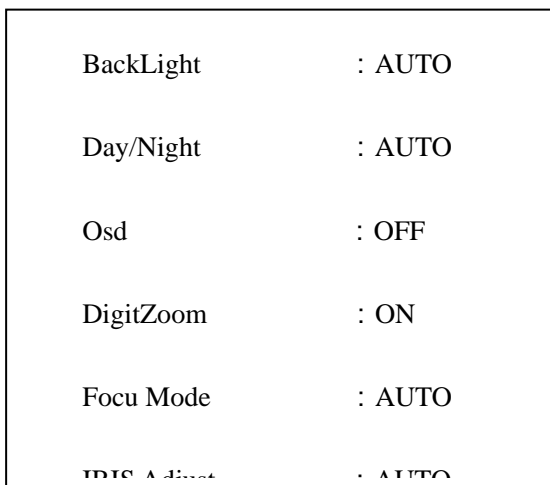
Move the cursor to next and move joystick right to enter the next submenu

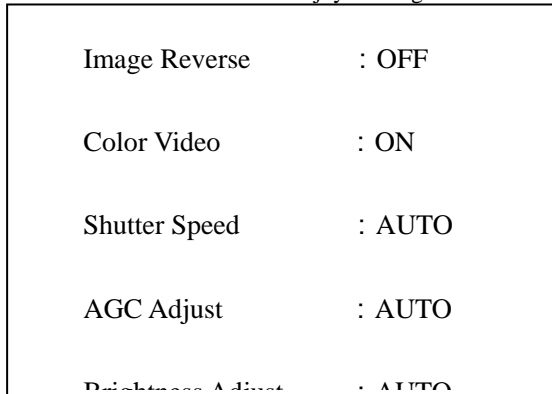

6-3-2

- ◆ Image Reverse : ON/OFF
- ◆ Color Video : ON/OFF
- ◆ Shutter Speed : AUTO/MANUAL
- ◆ AGC Adjust : AUTO/MANUAL
- ◆ Brightness Adjust : AUTO/MANU
- ◆ Zoom Speed : 7/6/5/4/3/2/1
- ◆ Focu Speed : 7/6/5/4/3/2/1
- ◆ Reset : default setting
- ◆ Next:

6.4 Preset control

Move the cursor to Preset Control

Move joystick right to enter the submenu

No	: 001
Title	:
Setting	
Call	

6-4-1

- 1) Move the cursor to NO:
Moving the joystick up or down to change the 0-9. move joystick right to confirm
- 2) Move the cursor to title
Moving the joystick up or down to select title

NO.001
Title.....
Setting
Call
Delete
Exit

- 3) Move the cursor to Call , you can call the preset position that has been set , if the preset position has not be set , the monitor will display

NONENITY

- 4) Exit

6-4-2

6.5 Special function

Move the cursor to Special Function

Move joystick right to enter submenu

The monitor will display

Proportional Pan	: ON
Auto Resume	: ON
Joystick Auto	: FOCUS
Auto Mode	
Auto Running	
Privacy Zone	

图 6-5-0

- 1) Proportional pan :ON/OFF
The pan speed of dome will lower to capture clear picture according to zoom in when the proportional pan is set to ON.
- 2) Auto resume : ON/OFF
ON: The dome will restart the situation after powerd up
- 3) Joystick auto : focus/none /both/iris

1. **Auto mode**

Move the cursor to auto mode
 Move joystick right to enter submenu
 The monitor will display

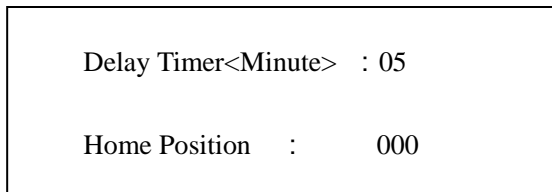

6-5-1

- ◆ Delay Timer : 01/02.....29/30 minutes
- ◆ Home Position : 001/002/.....079/080
- Mode Select : OFF/PATROL/SEQ
 AUTO TILT/AUTO PAN
 P2P SCAN/HOME/PTZ

2. **Auto running(Auto Pan Function)**

p2p scan

set left this P2P scan allows you to have the camera move back and forth automatically , at a preset speed ,between the 2 preset positions.

Move the cursor to auto running

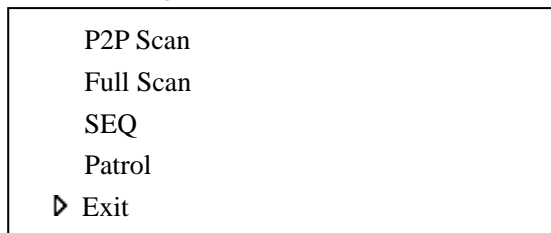

6-5-2

- 1. move the cursor toP2P Scan
 move joystick right to enter submenu
 the monitor displays:

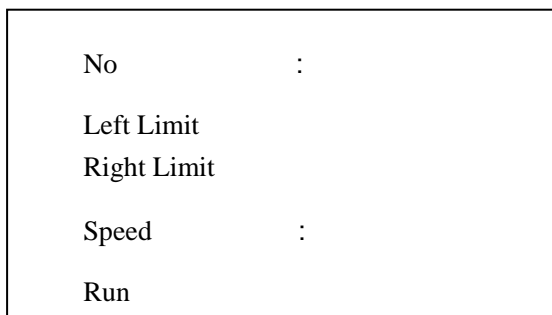

6-5-3

- 1) No: 1/2/3/4
Move the cursor to Left Limit
The monitor will display

Call No 1 To save Preset No 1 Esc Setting.....
--

Move joystick up , down , left , right , and zoom in , zoom out to select the position you want the [call]+[1]+[enter] to save and exit
Then set the right limit

- 2) Move the cursor to setting
Move joystick right to enter ,the monitor will display:

Call No 1 To Save Preset No 1 Esc Setting.....
--

Now move joystick up or down and zoom in or out to the position you wanted and [call]+[1]+[enter] to save and exit The monitor will display

- 3) Speed : 3/2/1/8/7/6/5/4
 "8" stand for high speed
 "1" stand for low speed
 - 4) Move to "Run", the dome will move back between the 2 preset positions
 - 5) Delete : to delete the setting
2. Full Scan
move the cursor to Full Scan
move joystick right to enter submenu
The monitor displays:

Mode : PAN Speed : 3

6-5-5

mode : pan/both/tilt
speed : 3/2/1/8/7/6/5/4
run : to scan automatically

3. SEQ (AUTO TOUR)
The preset position can be programmed to be recalled in a set of sequence .This sequence can e set to let the camera scan from one position the next in a cycle at a set speed.this feature is called auto cruise.
 - The camera can do auto cruise if inputing the preset position sequences into called auto cruise
 - Cruise sequence and dwell time of each preset can be set
 - Up to 16 presets can be memorized in each cruise tour

No : Title : Setting Run Delete ▶ Exit

6-5-6

NO: 1/4/3/2

Title :-----

Setting : to programe the tour

The monitor displays

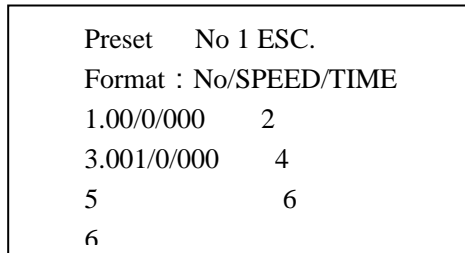

4. Patrol function

Patrol (path memory function)

With this function , the camera can memorize the pan/tilt movements and lens command of the dome within 30 seconds .4 pattern routes are available . Pattern memory is only applicable to the operation of pan/tilt and lens by OSD menu.

Move the cursor to Patrol

Move the joystick right to enter submenu

The monitor displays

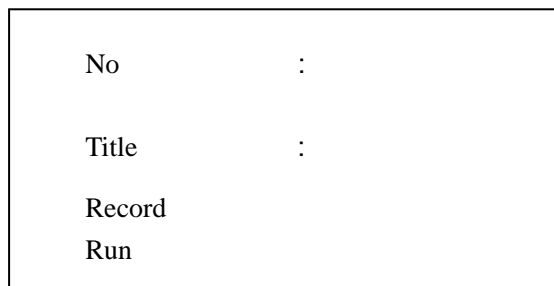

6-5-8

No : 1/4/3/2

Title :-----

Record : to programe patrol routing

The monitor will display

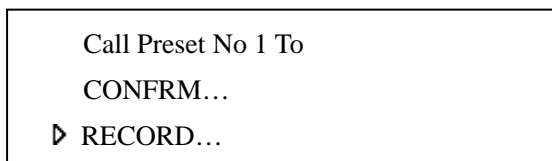

6-5-9

after setting , [call]+[1]+[enter]

to save and exit

the monitor will display

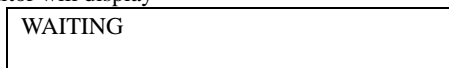

RUN: to run to patrol / tour you set

3. Privacy zone(Privacy masking setting)

When there is a house or even a window within the camera frame ,it is possible to make the area so that it will not appear on the monitor to protor to protect privacy .Up to 8 masks of arbitrary size are avaiable
 Move the cursor to privacy submenu
 The monitor will display

No: 1/8/7/6/5/4/3/2
 Set : to set the masking position

```

NO      1
Set
Active  ON  --  OFF
Show
▶ Exit
  
```

The monitor will display

```

PTZ POSITION
SCREEN POSITION
SIZE ADJUST
▶ EXIT
  
```

ENTER PTZ POSITION

```

PTZ POSITION
  
```

Now you move joystick up ,down , right , left , to select the position you want
 [call]+[1]+[enter] to save and exit
 move the cursor to SCREEN POSITION , and enter the submenu
 the monitor will display

```

SCREEN POSITION
  
```

Move the joystick tofind the start position you want to mask, [call]+[1]+[enter] to save and to size adjust
 Move the cursor to size adjust
 Move joystick right to enter submenu
 The monitor will display

```

SIZE ADJUST
  
```

Move joystick down or right to mask the position you want
 [call]+[1]+[enter] to save and exit
 Active : OFF/ON
 ON : the masking will display
 Show : to show the NO. x masking position

4. motion detection
now not used
5. Brush
Not used in speed dome
6. Alarm input
The monitor displays

Alarm in 1: 001
Alarm in2: 002
Alarm in 3: 003
Alarm in 4: 004
Mode : N.Open
Output: N.Open

6.6 Factory default

Move the cursor to Factory Default
Move joystick right to enter submenu
The monitor displays

FACTORY DEFAULT
NO YES

Move joystick left to say No
Move joystick right twice to say Yes

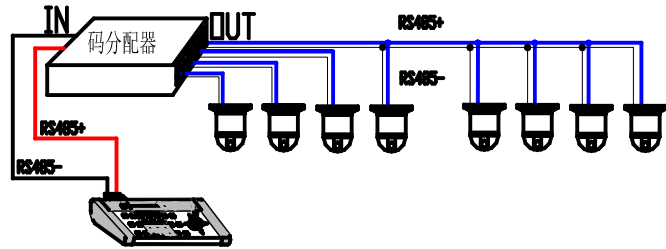

Appendix VIII : Warranty

1. Scope

- The factory warrants its dome camera products to be free from defect in materials and workmanship for a period of one year from the date of purchase. During this period the factory will repair or replace components of the product which proves to be defective.
- The factory warrants the repaired and replaced components for a period of 90 days from the date of dispatching repaired products.
- Defects of products caused by Force Majeure (such as war, earthquake, lightning strike and so on), abuse, non-standard operation, change of construction, normal wear or accident are void of warranty.
- Factory assumes no risk and shall be subject to no liability for damages or loss resulting from the specific use or application made of the products. Factory's liability for any claim, whether based on breach of contract, negligence, infringement of any rights of any party or product liability, relating to the products shall not exceed the price paid by the distributor to the factory. In no event will factory be liable for any special, incidental or consequential damages however caused, whether by the negligence of the factory or otherwise.
- For defective products exceeding the warranty period, the factory assures the user a lifetime payable service.

2. Products information

Should a product require service during the warranty period, please contact the factory to request an RAN number and ship the product to factory with the following information:

- Product mode and serial number;
- Date of purchase, purchase order number, sales confirmation number and invoice number;
- Detailed description of defect or malfunction.

If there is a dispute regarding the warranty of a product which does not fall under the warranty conditions stated above, please include a written explanation with the product when returned.

3. Shipping

To speed the shipping back of repaired product, user should request the RAN(Returned Authorization Number) number first and ship the product with a RAN label to the factory at user's own charges. Factory will adopt the same means of transportation as user does to ship back the repaired product. Factory will only bear the freight charges for shipping back.

4. Problems in practical connection

In some circumstances user adopts a star configuration in practical connection. The termination resistors must be connected to the two equipment that are farthest away from each other, such as equipment 1# and 15# in Picture 44. As the star configuration is not in conformity with the requirements of RS485 standards, problems such as signal reflections, lower anti-interference performance arise when the cables are long in the connection. The reliability of control signals is decreased with the phenomena that the dome does not respond to or just responds at intervals to the controller, or does continuous operation without stop (refer to Picture 44).

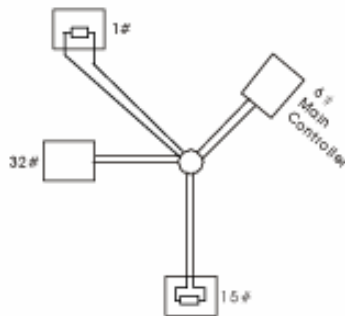

Picture 44

In such circumstances the factory recommends the usage of DR-HB16 RS485 distributor. The distributor can change the star configuration connection to the mode of connection stipulated in the RS485 standards. The new connection achieves reliable data transmission (refer to Picture 45).

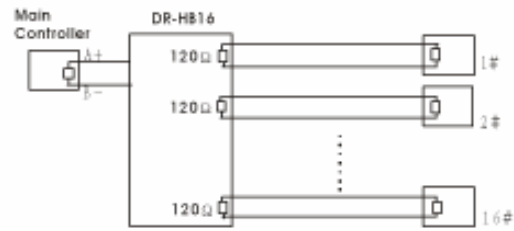

Picture 45

5. RS485 Bus Troubleshooting (refer to following form)

Trouble	Possible Cause	Solution
Dome can do self-testing but cannot be controlled.	<ol style="list-style-type: none"> 1. The address and baud rate settings of dome are not in conformity with those of controller. 2. The " + " and " - " connection of RS485 Bus is incorrect. 3. Wiring is not fully seated. 4. There is breakage in the middle section of the RS485 Bus. 	<ol style="list-style-type: none"> 1. Change the address and baud rate of controller or dome. 2. Correct the connection. 3. Make sure the connections are fully seated. 4. Replace RS485 Bus wires.
The dome can be controlled but the operation is not smooth.	<ol style="list-style-type: none"> 1. The RS485 Bus line is not in good contact with the connectors. 2. One wire of the RS485 Bus is broken. 3. The dome is very far away from controller. 4. There are too many domes connected in the system. 	<ol style="list-style-type: none"> 1. Secure the connection. 2. Replace RS485 Bus wires. 3. Add termination resistors to the system. 4. Install RS485 distributor.

Appendix III : RS485 Bus Basic Knowledge

1. Characteristics of RS485 Bus

As specified by RS485 standards, RS485 Bus is of half-duplexed data transmission cables with characteristic impedance as 120Ω . The maximum load capacity is 32 unit loads (including main controller and controlled equipment).

2. Transmission distances of RS485 Bus

When user selects the 0.56mm (24AWG) twisted pair wires as data transmission cable, the maximum theoretical transmitting distances are as follows:

Baud Rate	Maximum Transmitting Distance
2400BPS	1800m
4800BPS	1200m
9600BPS	800m

If user selects thinner cables, or installs the dome in an environment with strong electromagnetic interference, or connects lots of equipment to the RS485 Bus, the maximum transmitting distance will be decreased. To increase the maximum transmitting distance, do the contrary.

3. Connection and termination resistor

The RS485 standards require a daisy-chain connection between the equipment. There must be termination resistors with 120Ω impedance at both ends of the connection (refer to Picture 40).

Please refer to Picture 41 for simple connection. "D" should not exceed 7m.

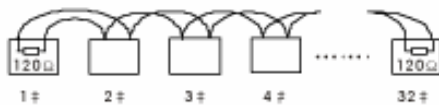

Picture 40

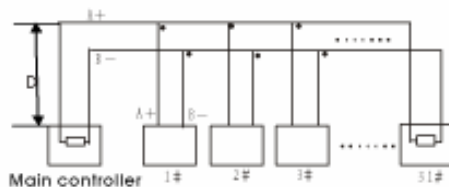

Picture 41

The connection of 120Ω termination resistor:

The termination resistor is ready on the Protocol PCB. There are two kinds of connection. Refer to the Protocol PCB jumper setting form (refer to Picture 42,43).

- 1) In the Picture it is the factory default connection. The jumper is seated on Pin2&Pin3 and the termination resistor is not connected.
- 2) when connecting the 120Ω termination resistor, user should pull out the protocol PCB and plug the jumper on Pin1&Pin2. Install the PCB back and the termination resistor is connected.

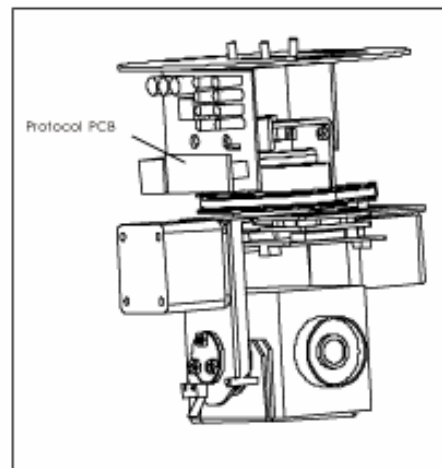

Picture 42

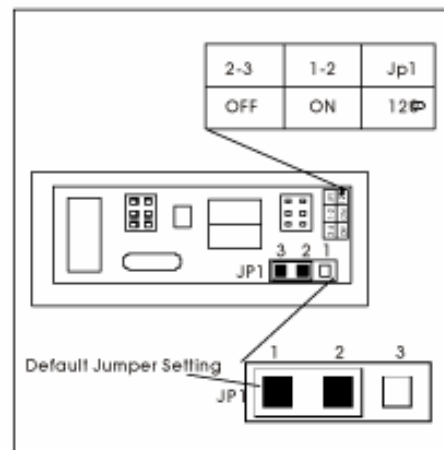

Picture 43

Appendix IV : Wire Diameter and Transmission Distance Comparison Chart

The transmission distances listed below are farthest ones recommended for each given wire diameter when the 24Vac voltage loss ratio is below 10% (for equipment powered by AC, the allowed maximum voltage loss ratio is 10%). For example, a set of equipment with nominal power as 80VA, installed 35 feet (10m) away from transformer, needs a wire with a minimum diameter of 0.8000mm.

		Wire Diameter (mm)			
		0.8000	1.000	1.250	2.000
Power (VA)	10	283 (86)	451 (137)	716 (218)	1811 (551)
	20	141 (42)	225 (68)	358 (109)	905 (275)
	30	94 (28)	150 (45)	238 (72)	603 (183)
	40	70 (21)	112 (34)	179 (54)	452 (137)
	50	56 (17)	90 (27)	143 (43)	362 (110)
	60	47 (14)	75 (22)	119 (36)	301 (91)
	70	40 (12)	64 (19)	102 (31)	258 (78)
	80	35 (10)	56 (17)	89 (27)	226 (68)
	90	31 (9)	50 (15)	79 (24)	201 (61)
	100	28 (8)	45 (13)	71 (21)	181 (55)
	110	25 (7)	41 (12)	65 (19)	164 (49)
	120	23 (7)	37 (11)	59 (17)	150 (45)
	130	21 (6)	34 (10)	55 (16)	139 (42)
	140	20 (6)	32 (9)	51 (15)	129 (39)
	150	18 (5)	30 (9)	47 (14)	120 (36)
	160	17 (5)	28 (8)	44 (13)	113 (34)
	170	16 (4)	26 (7)	42 (12)	106 (32)
	180	15 (4)	25 (7)	39 (11)	100 (30)
	190	14 (4)	23 (7)	37 (11)	95 (28)
	200	14 (4)	22 (6)	35 (10)	90 (27)

Transmission Distance (feet (m))

Appendix I : Lightning Proof and Surge Signal Proof

The product adopts TVS lightning proof technology to prevent from damage by lightning strike below 1500 W and impulse signals such as surge; but it is also necessary to abide by the following precautions to ensure electrical safety based on practical circumstances:

- Keep the communication cables at least 50 meters away from high voltage equipment or cables.
- Make outdoor cable laying-out under eaves as possible as you can.
- In open area shield cables in steel tube and conduct a single point ground to the tube. Trolley wire is forbidden in such circumstances.
- In strong thunderstorm or high faradic zone (such as high voltage transformer substation), extra strong lightning proof equipment must be installed.
- Take the building lightning proof requirements into account to design the lightning proof and grounding of outdoor equipment and cable laying-out in accordance with the national and industrial standards.

- The system must be grounded with equal potentials. The earth ground connection must satisfy the anti-interference and electrical safety requirements and must not short circuited with high voltage electricity net. When the system is grounded separately, the resistance of down conductor should be $< 4 \Omega$ and the sectional area of down conductor should be $< 25\text{mm}^2$ (refer to Picture 39).

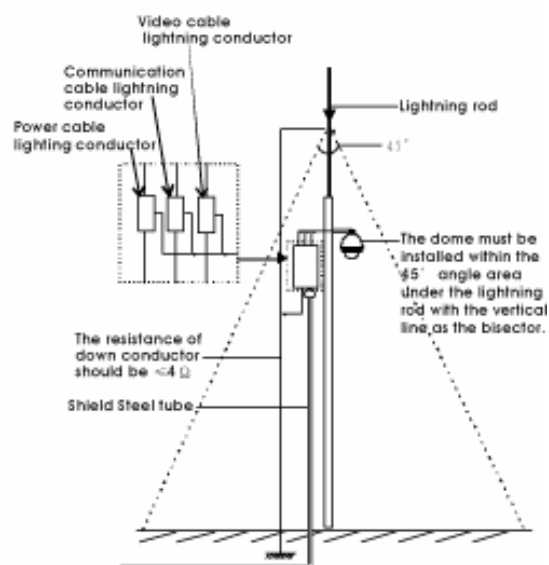

Picture 39

Appendix II : The Cleaning of Clear Down Cover

To obtain constant clear videos, user should clean the down cover periodically.

- Be cautious when cleaning. Hold the down cover ring only to avoid direct touch to the acrylic down cover. The acid sweat mark of fingerprint will corrode the coating of down cover and scratch on down cover will cause vague images.
- Use soft dry cloth or the substitute to clean the inner and outer surfaces.
- For hard contamination, use neutral detergent. Any cleanser for high grade furniture is applicable.

Appendix VIII : Warranty

1. Scope

- The factory warrants its dome camera products to be free from defect in materials and workmanship for a period of one year from the date of purchase. During this period the factory will repair or replace components of the product which proves to be defective.
- The factory warrants the repaired and replaced components for a period of 90 days from the date of dispatching repaired products.
- Defects of products caused by Force Majeure (such as war, earthquake, lightning strike and so on), abuse, non-standard operation, change of construction, normal wear or accident are void of warranty.
- Factory assumes no risk and shall be subject to no liability for damages or loss resulting from the specific use or application made of the products. Factory's liability for any claim, whether based on breach of contract, negligence, infringement of any rights of any party or product liability, relating to the products shall not exceed the price paid by the distributor to the factory. In no event will factory be liable for any special, incidental or consequential damages however caused, whether by the negligence of the factory or otherwise.
- For defective products exceeding the warranty period, the factory assures the user a lifetime payable service.

2. Products information

Should a product require service during the warranty period, please contact the factory to request an RAN number and ship the product to factory with the following information:

- Product mode and serial number;
- Date of purchase, purchase order number, sales confirmation number and invoice number;
- Detailed description of defect or malfunction.

If there is a dispute regarding the warranty of a product which does not fall under the warranty conditions stated above, please include a written explanation with the product when returned.

3. Shipping

To speed the shipping back of repaired product, user should request the RAN(Returned Authorization Number) number first and ship the product with a RAN label to the factory at user's own charges. Factory will adopt the same means of transportation as user does to ship back the repaired product. Factory will only bear the freight charges for shipping back.