

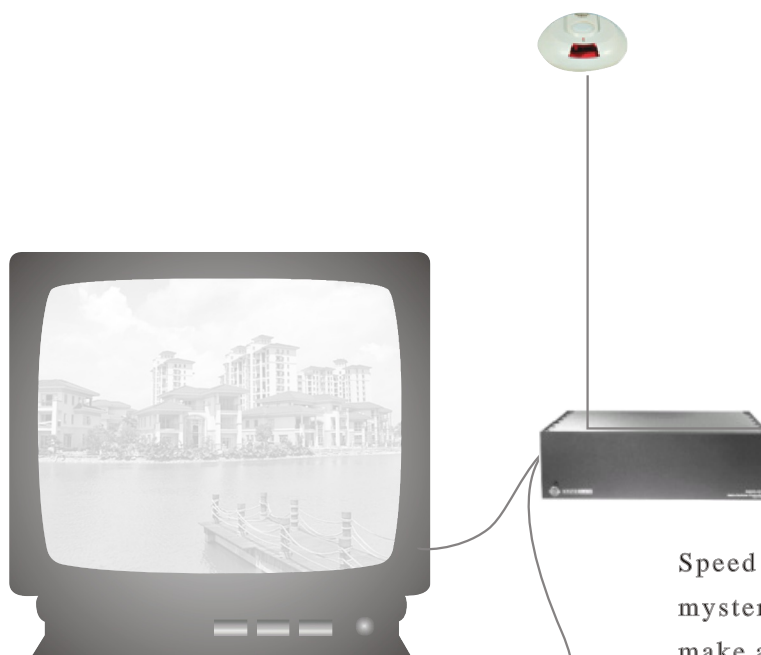

HIGH SPEED DOME OPERATION MANUAL



Speed dome camera looks like a mysterious owl at night, quiet, make a comprehensive view, be sensitive to catch.



Table of Content

1. Precation	1
2. Performance	2
2.1 Speed dome technology parameter	2
2.2 Camera parameter	2
2.3 Performance & Feature	3
3. Function instruction	4
3.1 Set camera ID	4
3.2 Auto-run motion	4
3.3 Camera control	5
3.4 Monitor function	5
4. System setting	7
4.1 Basic operation	7
4.1.1 Self-testing	7
4.1.2 Call the main menu	7
4.1.3 The operational ways of keyboard and menu	7
4.2 Edit dome label	8
4.3 Display initial information	9
4.4 Display setting	10
4.5 System setting	11
4.5.1 Auto flip	11
4.5.2 Speed proportion pan	11
4.5.3 Park action	12
4.5.4 Power up action	12
4.6 Clear	13
5. Camera setting	14
5.1 Zoom speed	14
5.2 Digital zoom control	15
5.3 Back light compensation	16
5.4 Slow shutter	17
5.5 IR cut filter	18
5.6 Line Sync control	19
5.7 Advance setting	20
5.7.1 AE mode	20
5.7.2 White balance mode	21
6. Function setting	22
6.1 Preset seting	22
6.2 Scan	23
6.3 Pattern	24
6.4 Tour	25
6.5 Zone setting	26
7. Privacy zone masking	27
8. Alarm	28

9. Appendix	29
9.1 Menu index	29
9.2 Troubleshooting	30
9.3 The cleaning of the down cover	31
9.4 Rs485 Bus Basic Knowledge	32
9.5 DIP Switch setting	34
9.5.1 Baud rate setting	34
9.5.2 Protocol setting	34
9.5.3 ID setting	34

1. Precaution

➤ **Electrical safety**

Conform to country and local electrical safety standard when using or installing the product.

➤ **Transportation**

The dome should be protected against extremes of pressure, vibration and humidity during storage and transportation. It should be shipped in parts disassembled as the original packing did. Damage caused by improper transportation is not within the warranty.

➤ **Installation of care**

Do not install it in any other orientation. Do not squeeze structure parts, which may cause mechanical damage. Down cover is a precise optical product. Do not touch it directly to avoid scratches which can affect image quality.

➤ **Requirements to service personnel**

All the service work should be done by qualified technicians.

➤ **Do not disassemble the pan/tilt module**

Do not disassemble screws and open the dome cover, as there are no users serviceable parts inside. Only qualified and authorized personnel may undertake repairs.

➤ **Environmental requirements**

● Requirements for indoor dome:

Environmental temp: -10 ~ +50 °C

Humidity: <90%

Air pressure: 86~106Kpa

AC Power supply: 24V/1000MA, 50/60HZ

● Requirements for Outdoor dome:

Environmental temp: -40~+60 °C

Humidity: <90%

Air pressure: 86 ~ 106Kpa

AC Power supply: 24V/2500MA, 50/60HZ

➤ **Don't place the camera to be shoot by strong light objects**

Don't place the camera to be shoot by strong light objects. Don't point the dome to the sun or other bright objects when in use or not. It may affect image quality.

➤ **Function of waterproof**

The outdoor dome has functions of waterproof, damp-proof, dustproof, and accord with IP66 international standard. The indoor dome doesn't install in outdoor environment where there is filled with hydrosphere. No matter the indoor dome or the outdoor dome should avoid dropping which affect element quality.

2.1 Speed dome technology parameter

Electrical:		Setting:	
Power supply	AC24V	Baud rate (RS485)	2400/4800/9600/19200bps
Consumption	Indoor12W, outdoor50W	Protocol	Pelco/KALATEL/PHILIPS/DIAMOND,and seventeen protocols,etc.
Operation:		Address setting	0-255
Decoder	Built-in	Environmental:	
Pan rotation	360° continuously	Operational environment	-40 — +60°C (outdoor)
Tilt rotation	Tilt90° , with auto flip	Environmental humidity	0—95% no compensation
Rotation speed	Pan0.4~320° /S Tilt0.4~120° /S	Protection grade	IP66,Weather proof housing, TVS1500w lightning proof surge proof
Alarm function	7 alarm input/2 alarm output	Physical:	
Preset	128presets	mount	Wall/pole/corner/pendant
Monitor way	preset/tour/scan/pattern	Weight(no bracket)	4.25kg (indoor) /3.85kg (outdoor)
Speed	Magnification and proportion pan	Material	All aluminium structure

2.2 camera parameter

TYPE SPEC	A : 18X Color	B : 18X Color	C : 18X Color/Mono	D : 26X Color/Mono	H : 22X Color	K : 22X Color	J : 23X Color/Mono	R: 16X Color	Q: 16X Color	S: 18X Color/ Mono	T: 23X Color/ Mono	
Sync system	Internal	external/internal						Internal				
CCD	1 / 4”											
Scan system	2:linterlacing											
Definition	470Lines	480 Lines	480 Lines	480 Lines	480 Lines	480 Lines	480/570 Lines	420 Lines	480 Lines	480 Lines	480 Lines	
Sensitivity	0.9Lux	0.7Lux	Color0.7Lux Black/white0.01Lux	Color0.7Lux Black/white0.01Lux	0.9Lux	0.01Lux	Color0.8Lux Black/white0.01Lux					
Iris	Auto/manual											
Focus	Auto/manual											
Magnification	216X (18X, 12X)		312X (26X, 12X)		264X (22X, 12X)		230X (23X, 10X)		128X (16X, 8X)		216X (18X, 12X)	230X (18X, 10X)
Zoom length	4.1—73.8mm			3.5—91mm		4—88mm		3.6—82.8mm		3.9—63mm		3.6— 82.8mm
View of angle	W48° T2.7°			W54° T2.2°		W47° T2.2°		W54° T2.4°				
Back light compensation	Off/Auto						Off					
Gain control	Auto/manual											
Shield window	setable				None		setable		None			
Signal format	PAL/NTSC						PAL					
S/N	≥50dB				≥48dB		≥50dB		≥48dB			
Video output	1.0±0.2V _{P-P}											
Video output	Female BNC											
Slow shutter	None	setable			None		setable		None			

2.3 Performance and feature

A series of DOMENOR integrate with high speed dome camera is latest design with AMP electrical outlet, built-in constant device, convenient installation, and black cover which make an invisible surveillance. The camera rotates smartly with little noise, and has all kinds of functions, in order to supply perfect image to customer.

➤ **Built-in receiver**

- All configurable options stored in main control board to protect against power cuts
- Integrate design and high durability
- 80 presets can be stored at will, and support auto-tour, and each tour can store up to 27 presets.
- 4 pattern tours
- 1 scan
- Built-in direction indicator
- Built-in temperature indicator
- Rs485 Bus communication or American Dynamics Manchester code or coaxial video cable
- 24 masking zones
- 7 alarm input, 2 alarm output

➤ **Built-in pan/tilt**

- Aluminum alloy structure, high intensity, good dispelling the heat.
- Precise stepping motor drives the pan to run smoothly and react sensitivity.
- Integrated design, compact structure, easy to remove.
- Exquisite mechanical drive, support to rotate pan 360° continuously and tilt 0-90° , and may rotate 180° with auto flip.
- Pan 0.4° /s to rotate slowly, and the image doesn't vibration.

➤ **Built-in digital camera**

- High sensitivity, high resolution, and integrated digital processing
- Auto-focus
- Auto-Iris
- Auto brightness control
- Auto white balance
- IR cut filter
- Auto back light compensation
- Auto slow shutter

➤ **OSD menu**

- All English menu can be selectable.
- Visual OSD menu. Revising the speed dome's information and parameter by keyboard and OSD menu, and it is easy to operate.
- Set park action function and set presets, or run scan, pattern, tour, etc during out of service.
- Auto-resume movement or carry out pointed movements after power up.

➤ **External temperature test**

- Set time display
- When the temperature exceeds the limit, the screen will display alarm information.
- When the temperature is less than the limit, the speed dome will delay to star, and when the heat device is heated and got higher than low limit temperature to star.
- According to the temperature, the fan measures if it is to start or not, and prolong the life of fan.

3. Function Instruction

This passage mainly describes the speed dome's main functions and principles, and do not refer to detail operation ways. Different systematic platform has uncomplete same detail operations, as usual according to manufacturer's operation manual, under some conditions there are some particular requirements and operations. Please contact dealer to gain necessary information.

3.1 Camera ID

Use 8-bit DIP Sw1 is for setting the speed dome address, and Sw 2 is for setting communication baud rate and controlling protocol. (For detail setting, please refer to 9.5 DIP switch setting)

The speed dome is compatible with various controlling protocols, such as PECLO-D、ALEC、VCL、MOLYNX、VICON、SANTACHI、PANASONIC、SAMUNG、BIAMOND、KALATEL、LILIN、ADT、HUNDA、ADT、PHILIPS、AD、UNIVISION, and so on. All the controlling command must base on the objective camera address, and the camera just reacts to the controlling command set to its own address. There are three kinds of camera address:

- **Switch address:** Use camera' switch number to set address 1-8 bits, the address range is 1-254.
- **Broadcast address:**(Only can be set by factory protocol and Pelco) If user chooses broadcast address to control, all the cameras connected with the control system will react to the same commands. When set as factory protocol, the broadcast address is 255.
- **Debug address:** (Only can be set by factory protocol and Pelco) if the ID of the camera is set 0, user may select any address to control the dome.

3.2 Auto-run motion

➤ Focus/speed proportion pan

When manually adjusting, for far focus situation, the dome responds at a high-speed so that touching rocker slightly may make picture move rapidly, thus cause the picture to lose. To base on humanized design, the dome automatically adjust pan and tilt rotation according to zoom near and far, which make it is convenient to operate manually to run after object. In the menu, you may change system parameter setting proportion pan as ON, thus you may run this function.

➤ Auto flip

If user holds the joystick in the down position, the camera rotates pan 180 degrees, after the camera rotates tilts up to 90 degrees, you may directly watch the rear view to surveillance all processes in portrait 180 degrees. In the menu, you may set the system parameter setting AUTO FLIP as ON, thus you may run this function.

➤ Park action

By the menu “ park time” and “park action” , user may set auto-call preset 1 or run tour, pattern, and scan, etc after pointing a few minutes if the dome doesn't run any motions.

➤ Power up action

By the menu “ power up action” , after the dome powers up or restarts, user may set auto-resume movements before power up and auto-call preset 1 or run tour, pattern, and scan etc .

3.3 Camera control

➤ **Magnification control**

The user can adjust zoom far and near of the image by keyboard controller “Wide/Tele” to obtain panoramic image or close view that you need. The speed dome support digital zoom and optical zoom, the digital zoom can be set.

➤ **Focus control**

System defaults Auto focus. When the lens changes, camera will auto-adjust focus according to the centre of the image to get legible image; user also can manually focus to get desire image by operating keyboard “FAR/NEAR” . When operating keyboard joystick, camera resumes to auto focus.

The camera cannot auto focus in the following status:

- Target is not the centre of the image
- Near and far targets in the same picture can not be clear at the same time.
- Target is a strong light object, such as spotlight & etc.
- Target moves too fast
- Target area such as wall
- Target is too dark or vague
- Target image is too small

➤ **Iris control**

System defaults Auto Iris. Camera can adjust immediately in accordance with the alteration of background illumination to reach a image with stable brightness.

User may adjust Iris by controller keyboard “open/close” to get required brightness that you need. User also can resume auto Iris by joystick operation. When controlling the Iris manually, the dome locks current position you manually controlled; when operating joystick, the dome resume auto Iris.

➤ **Auto back light compensation**

Camera sub-area can carry out auto back light compensation. Under a strong light background, camera will auto compensate light for the darker object and adjust daylight to the bright background. In order to avoid making the image mess by the background is too high in luminance, and the object is unable to recognize because of darkness, thus gain legible image.

➤ **Auto white balance**

Camera can automatically adjust white balance in accordance with the alteration of background lightness to reach a true colour.

3.4 Monitor function

➤ **Set and call preset**

Preset function is that dome stores current pan/tilt angle, zoom and other position parameters into the memory. When necessary dome recalls these parameters and adjust camera to that position. User can store and recall presets easily and promptly by using keyboard controlling. The dome can store up to 80 presets.

➤ **Tour**

Auto tour is the built-in function in the speed dome, is to make preset arranged in needful order in tour queue by programming in advance. To make camera tour between presets by inserting presets in cruise tour. It is feasible to program tour order, each time as you run tour, you can set the park time of preset. A tour can store 32 presets.

➤ The operator can prompt set right limit and left limit in advance by keyboard and menu, so as to make the camera repeatedly scanned between right and left limit at setting speed.

➤ **Pattern**

Pattern is built-in function in camera; the speed dome can record tracks that are no less than 180s, when running pattern, the dome moves repeatedly according to the recorded tracks. A dome can set up to 4 pattern tours.

➤ **Privacy zone masking setting**

The user can set a black shadow to mask the area so that it will not appear on the monitor to protect privacy.

➤ **Alarm input/output control**

The speed dome receive a external alarm message, it will carry out presetting movement in advance until alarm release to reset , if unusual, it will send another alarm message. The speed dome support up to 7 alarm input, 2 alarm output.

➤ **Lens position display**

The position that the speed dome has finished to auto-checking as 0 point of pan movement and tilt movement. The pan range is 0-360° , and tilt range is 0-90° . According to the displayed information, to set the position of camera lens, and the position can display on the screen.

4. System setting menu

4.1 Basic operation

4.1.1 Current-carrying to dome and Self-testing

The dome conducts self-testing after current-carrying, and it rotates slowly until displaying pan origin that is default setting, then moving to tilt origin, the lens is adjusted from far zoom to near zoom, or from near zoom to far zoom, when self-testing is finished, there is relevant system information displaying on the screen, as follow:

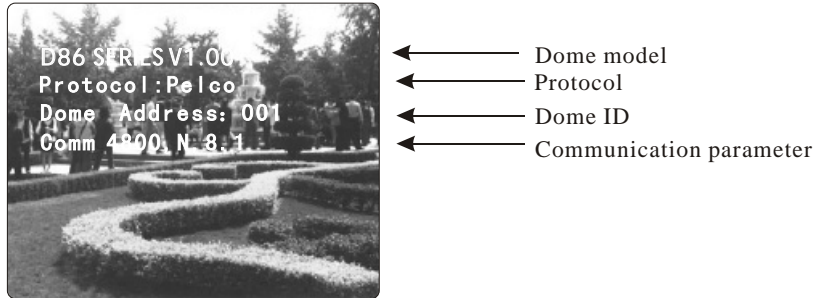

The information will not disappear until you stop to operate the system. If you set “power up action”, the dome will automatically activate motions after self-testing. How to operate the function? We will explain detail introduction in following passages.

4.1.2 Call the main menu

The system enters into the main menu by 95 preset. All the menu setting must enter into the main menu at first.

4.1.3 Menu and keyboard operation

➤ Keyboard operation:

【OPEN】 when choosing pictures, it means to increase Iris; when setting menu, it means to enter into the next menu or setting, or save after finishing setting.

【Close】 when choosing pictures, it means to reduce Iris; close to cancel.

【FAR】 Focus to far

【NEAR】 Focus to near

【TELE】 Increase magnification

【WIDE】 Reduce magnification

Joystick to up: When choosing menu, it means to choose the former one; when choosing picture, it means camera tilt up.

Joystick to down: when choosing menu, it means to choose the next one; when choosing picture, it means camera tilt down.

Joystick to left: when choosing menu, it is equal with [Close], when choosing picture, it means camera tilt left.

Joystick to right: when choosing menu, it is equal with [Open], when choosing picture, it means camera tilt right.

Press [TELE] and [WIDE] at the same time, it means 3D joystick rotates joystick cap.

➤ Menu operation

“Back” : Back to the former menu

“Exit” : Exit to menu

“On” : Open some setting

“Off” : Close some setting

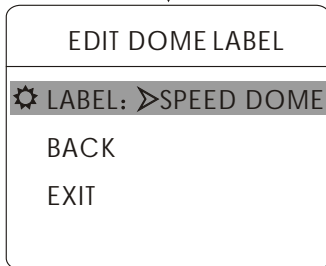
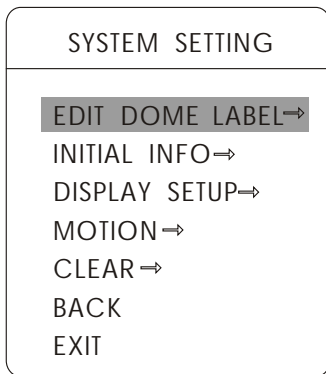
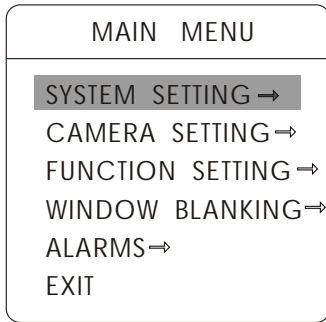

4.2 Edit dome label

When using a lot of domes' systems, in order to identify to each dome, the systems support title setting. The setting ways as follow:

- 1、 To use 95 preset to enter into the main menu.
- 2、 Moving joystick up and down to move the cursor to [SYSTEM SETTING], and pressing [Open] to enter into the next menu.
- 3、 Moving joystick up and down to move the cursor to [EDIT DOME LABEL], and pressing [Open] to enter into the label setting menu.
- 4、 Moving joystick up/down to move the cursor to [Label], and pressing [Open] to edit current label.
- 5、 When the cursor is twinkling in the first character of the label, to move joystick to choose character, after editing, pressing [Open] to save.
- 6、 Moving joystick to [Back] and pressing [Open] to back to the former menu.



Notice: The label may set 16 characters, and doesn't need editing characters. Pressing [Open] continuously to jump over and using spacebar to replace the deleted characters. When you finish to edit a character, pressing [Open] to enter into the next editing character; when you editing the last character, pressing [Open] to save.

Press [Close] to exit.

Character of label is suitable for choosing as follow: 0-9、 A-Z、 :<>-.、 Space.

Other label input way is the same.

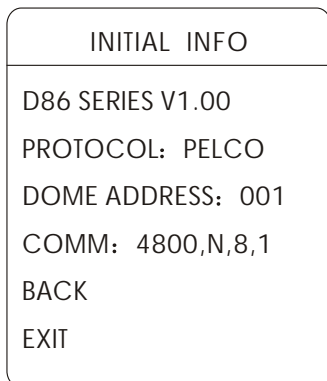
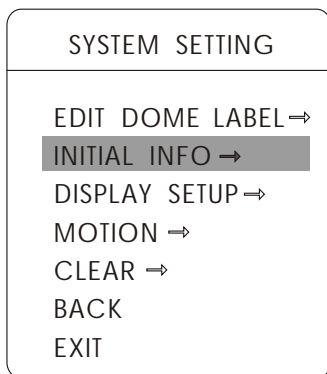
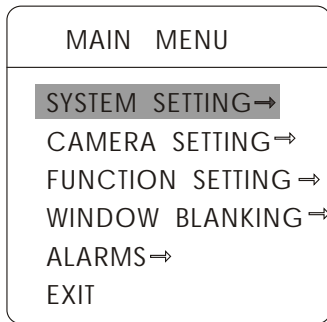

4.3 Display initial information

- 1、 Use 95 preset to enter into the main menu.
- 2、 Tilt up/down joystick to [SYSTEMSETTING], press [Open] to enter submenu.
- 3、 Tilt up/down joystick to [INITIALINFO], press [Open] to display initial information, which as below the left picture shows:

Initial information includes the name of manufacturer, soft edition, camera address, communication parameter. System setting may change the numerical value of initial information.

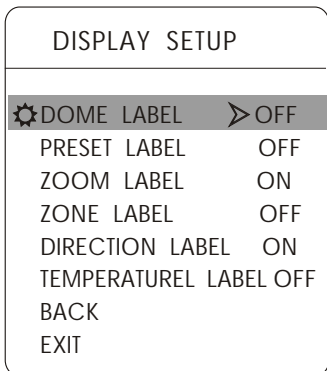
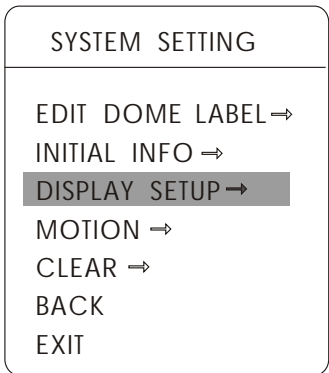
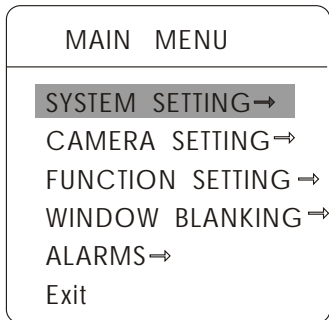

4.4 Display setup

- 1、 Use 95 preset to enter into the main menu.
- 2、 Tilt up/down joystick to [SYSTEMSETTING], press [Open] to enter submenu.
- 3、 Tilt up/down joystick to [DISPLAY SETUP], press [Open] to enter “display setup” menu, May setting the content of the display setup as follow:

- 【DOME LABEL】 dome label display setting
- 【PRESET LABEL】 preset label or scan label display setting
- 【ZOOM LABEL】 magnification display setting
- 【ZONE LABEL】 zone label display setting
- 【DIRECTION LABEL】 direction label display setting
- 【TEMPERATURE LABEL】 temperature label display setting

- 4、 Displaying dome label as an example to explain the process. Tilt up/down joystick to move cursor to [DOME LABEL OFF], press [Open], there is a sign ⚙️ besides [DOME LABEL], the cursor is twinkling besides [OFF], as left picture shows;

- 5、 Joystick tilts up/down, setting switch between ON/OFF, when displaying [ON], it means to display “dome label”, press [Open], the cursor jump back to [DOME LABEL], label setting is finished, move the cursor to [EXIT], exit to the menu setting.

The displaying information on the screen will change with the dome rotation; user may find out the external temperature, magnification, display zone etc by display information. when all the labels are displayed, the dome works as the following picture shows: (In the picture “305” means pan angle, “45” means title angle.)

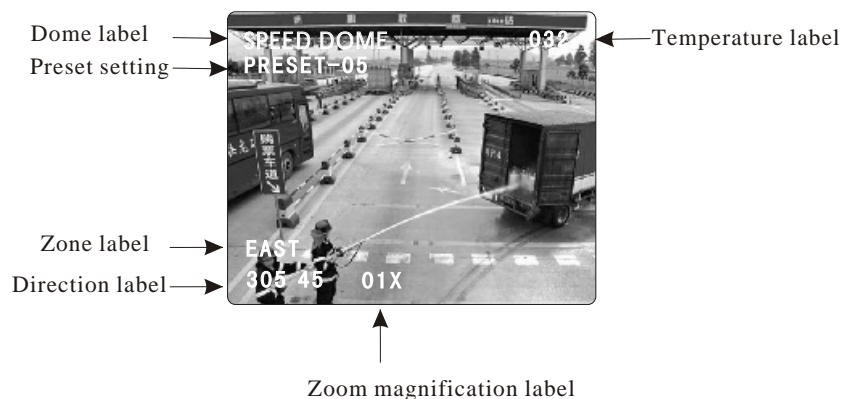

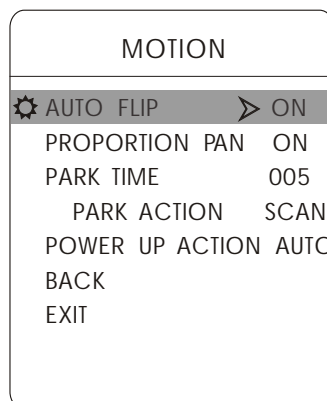
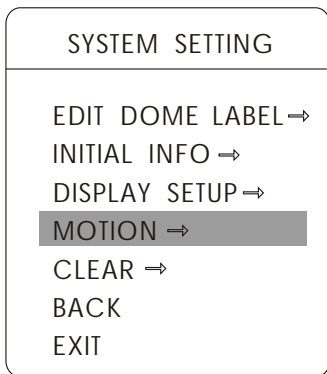
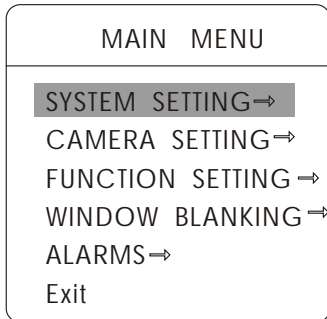

4.5 Systematic motion control

Systematic motion controlling may control a series of movement criterion of the dome, and plays an important role in controlling the image of the dome.

- 1、 Use 95 preset to enter into the main menu.
- 2、 Tilt up/down joystick to [SYSTEMSETTING], press [Open] to enter submenu.
- 3、 Tilt up/down joystick to [MOTION], press [Open] to enter systematic motion controlling menu, as left picture shows.

4.5.1 Auto flip

- 1、 Operate joystick, move the cursor to [AUTO FLIP]: press [Open] to enter “ auto flip ” setting, tilt up/down joystick, for example: choosing ON to open “ auto flip ” ; choosing OFF to close “auto flip” . Press [Open] to save.



Operation knacks

When opening the auto flip function, user holds the joystick in the down position, the camera rotates pan 180 degrees, after the camera rotates tilts up to 90 degrees, you may directly watch the rear view to surveillance all processes in portrait 180 degrees.

4.5.2 Speed proportion pan

- 1、 Operate joystick, move the cursor to [PROPORTIONAL PAN]; press [Open] to enter “ proportion pan ” setting, tilt up/down joystick to choose, if choosing [ON], it means to open proportion pan; if choosing [OFF], it means to close proportion pan , press [Open] to save.



Operation knacks

When manually adjusting, for far focus situation, the dome responds at a high-speed so that touching rocker slightly may make picture move rapidly, thus cause the picture to lose. To base on humanized design, the dome automatically adjust pan and tilt rotation according to zoom near and far, which make it is convenient to operate manually run after object.

MOTION	
AUTO FLIP	ON
PROPORTION PAN	ON
⚙️ PARK TIME	➤ 005
PARK ACTION	SCAN
POWER UP ACTION	AUTO
BACK	
EXIT	

4.5.3 Park action

This setting allows the dome to run an appointed action after out of service for a few time (1-240minutes). If default sets as 0, it means not to run this action.

1、 Operate joystick, move the cursor to [PART TIME], press [OPEN] to tilt up/down joystick to set park time, the range is 0-240 (minute), press [OPEN] to save.

[PART ACTON] is running action at park time, when [PART TIME] sets as 0, this item can't be set.

2、 Operate joystick, move the cursor to [PART ACTON], press [OPEN], there will be a sign ⚙️ in the front of [PART ACTON], the cursor jump to right, after tilting up/down joystick to choose “ park action” , there are options for choosing as follow, press [OPEN] to save.

- **【NONE】** - (default) none action
- **【PRESET】** -use preset 1
- **【SCAN】** -run scan
- **【PAT X】** - run pattern X
- **【TOUR】** - run tour

4.5.4 Power up action

The dome stats to run actions after self-testing, if nobody intervenes with it , the dome will repeatedly run this action continuously , if default sets as [AUTO].

1、 Operate joystick, move the cursor to [POWER UP ACTION]: press [OPEN] to jump to the following choice, tilt up/down joystick to choose “power up action” , press [OPEN] to save.

- **【NONE】** - none action
- **【AUTO】** - the dome resumes the primary action and direction before power up.

- **【PRESET】** - use preset 1
- **【SCAN】** - run scan
- **【PAT X】** - run pattern X
- **【TOUR】** - run tour

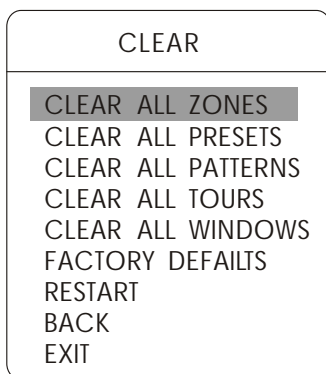
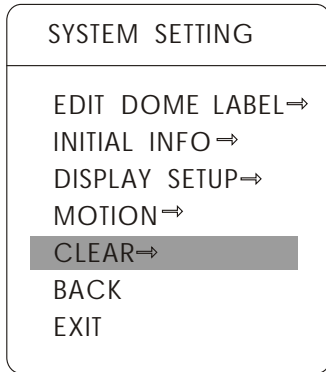
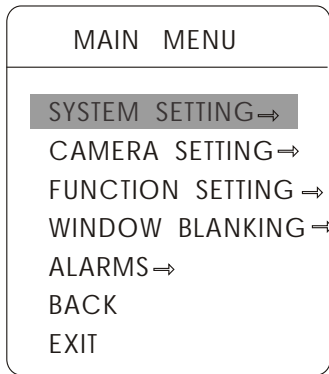

4.6 Clear

- 1、 Use 95 preset to enter into the main menu.
- 2、 Tilt up/down joystick to [SYSTEMSETTING], press [OPEN] to enter submenu.
- 3、 Tilt up/down joystick to [CLEAR], press [OPEN] to enter submenu, as left picture shows.

- **【CLEAR ALL ZONES】**
- **【CLEAR ALL PRESETS】**
- **【CLEAR ALL PATTERNS】**
- **【CLEAR ALL TOURS】**
- **【CLEAR ALL WINDOWS】**
- **【FACTORY DEFAULTS】** :resume the factory default. Run this function, the camera parameter and system parameter will resume before production, clear all windows and alarm setting. Please be cautious to use this function.

- 4、 Set clear zone as an example to explain the process. Tilt up/down joystick to [CLEARALLZONES], press [OPEN] to clear all zones.



Notice: once clear all commands in the controlling menu, they doesn't resume, so please be careful of using.

5. Camera setting

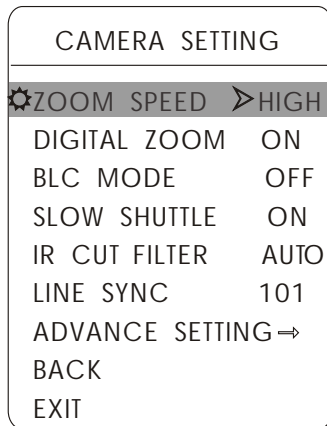
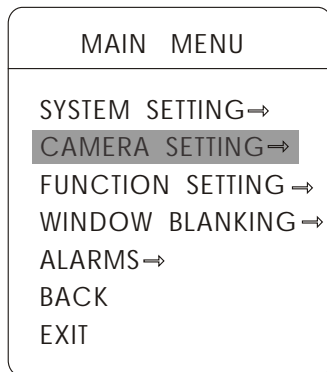

5.1 Zoom lens

1. Use 95 preset to enter into the main menu.
2. Tilt up/down joystick to [CAMERASETTING], press [OPEN] to enter submenu;
3. Operate joystick, move the cursor to [ZOOM SPEED]; press [OPEN] will appear a sign ⚙ in the front of [ZOOM SPEED], the cursor moves to right, tilt up/down joystick to choose [HIGH] or [LOW];
4. Press [OPEN] to save, press [CLOSE] to cancel.

5.2 Digital zoom control

MAIN MENU	
SYSTEM SETTING	→
CAMERA SETTING	→
FUNCTION SETTING	→
WINDOW BLANKING	→
ALARMS	→
BACK	
EXIT	



CAMERA SETTING	
ZOOM SPEED	HIGH
⚙️ DIGITAL ZOOM	➤ ON
BLC MODE	OFF
SLOW SHUTTLE	ON
IR CUT FILTER	AUTO
LINE SYNC	101
ADVANCE SETTING	→
BACK	
EXIT	

1. Use 95 preset to enter into the main menu.
2. Tilt up/down joystick to [CAMERASETTING], press [OPEN] to enter camera setting;
3. Operate joystick, move the cursor to [DIGITAL ZOOM], press [OPEN] to enter digital zoom setting, tilt up/down joystick, to choose ON means open digital zoom control which is digital zoom is pulled near, if pulling the digital zoom near again, the dome enters into “ digital zoom increase” ; to choose OFF means to close digital zoom control.
4. Press [OPEN] to save.



Operation knacks

When digital zoom be set as ON, the maximum zoom magnification of the dome is digital zoom magnification products optical zoom magnification; when digital zoom be set as OFF, the maximum zoom magnification of the dome is optical zoom magnification.

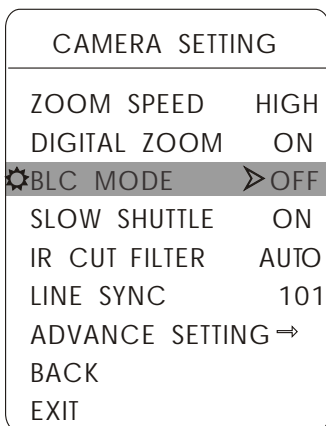
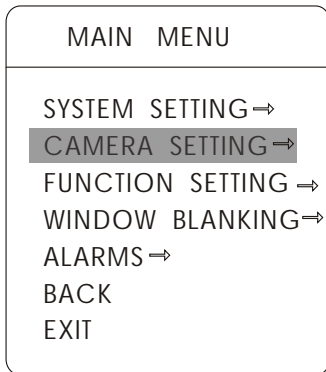

5.3 Back light compensation

1. Use 95 preset to enter into the main menu.
2. Operate joystick, move the cursor to [CAMERA SETTING] to enter submenu.
3. Operate joystick, move the cursor to [BLC MODE], press [OPEN], There will be a sign ⚙️ in the front of [BLC MODE], the cursor jump to right, tilt joystick to open or close back light compensation function. If choosing ON means to open back light compensation mode; if choosing OFF means to close back light compensation mode;
4. Press [OPEN] to save.



Operate knacks

Strong background ray can make backlighting objects engender shadow, (back light compensation), the speed dome can auto-adjust iris to match with the changes of various ray, and auto-revise the main lightness, to make the pictures more legible.



Non-use back light compensation, in strong sunshine, the backlight side is subject to dark.



Use back light compensation, the image is in gear

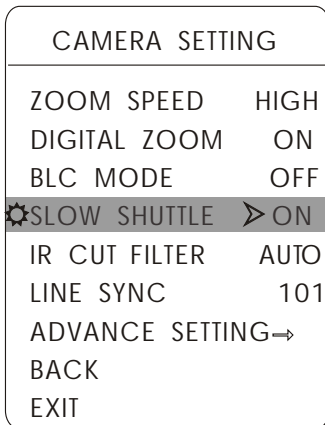
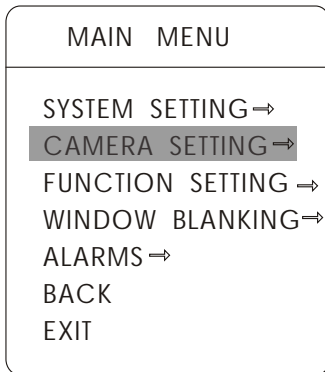

5.4 Slow shutter control

- 1、 Use 95 preset to enter into the main menu.
- 2、 Operate joystick, move the cursor to [CAMERA SETTING] to enter submenu.
- 3、 Operate joystick, move the cursor to [SLOW SHUTTLE], press [OPEN], there will be a sign ⚙️ in the front of [SLOW SHUTTLE], the cursor moves to right, tilt up/down joystick to “slow shutter” function choice, if choosing ON means to open slow shutter function, if choosing OFF means close slow shutter function.
- 4、 Press [OPEN] to save.



Operation knacks

When the dome monitors at night or dark environment, because the ray is not enough, the image on the screen is too dark, setting slow shutter can lengthen the time of lighting so that make the picture that is shoot in dark more legible.

MAIN MENU	
SYSTEM SETTING →	
CAMERA SETTING →	
FUNCTION SETTING →	
WINDOW BLANKING →	
ALARMS →	
BACK	
EXIT	



CAMERA SETTING	
ZOOM SPEED	HIGH
DIGITAL ZOOM	ON
BLC MODE	OFF
SLOW SHUTTLE	ON
IR CUT FILTER	▷ AUTO
LINE SYNC	101
ADVANCE SETTING →	
BACK	
EXIT	

5.5 IR cut filter

- 1、 Use 95 preset to enter into the main menu.
- 2、 Operate joystick, move the cursor to [CAMERA SETTING] to enter submenu.
- 3、 Operate joystick, move the cursor to [IR CUT FILTER]; press [OPEN], there will be a sign  in the front of [IR CUT FILTER], the cursor jumps to right, move joystick to “ IR cut filter” , choices as follow, [AUTO] is default.

- **【AUTO】** IR cut filter mode, it means the dome automatically transfers according to sensitivity.
- **【COLOR】** set as color image mode
- **【BLACK】** set as black and white image mode

- 4、 Press [OPEN] to save.



Operation knacks

IR cut filter function uses color in day; use black and white at night. This function not only guarantees the quality of image, but also saves the room of storage.

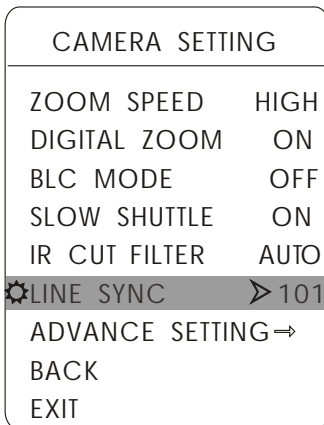
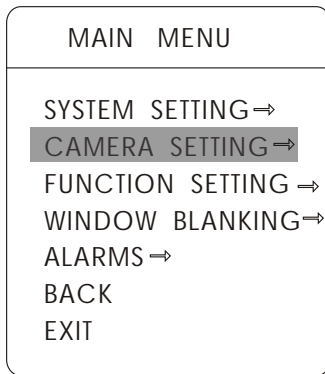

5.6 Line sync control

- 1、 Use 95 preset to enter into the main menu.
- 2、 Operate joystick, move the cursor to [CAMERA SETTING], press [OPEN] to enter submenu.
- 3、 Operate joystick, move the cursor to [LINE SYNC]; press [OPEN], tilt up/down joystick to set line sync. Line sync can divide two kinds: internal/external, choose OFF is internal sync; choose other numerical value (1-359) is external sync; press [OPEN] to save.



Operation knacks

When a lot of domes use a line in the same time, if the image is twinkling as switching, please set each dome as external line and adjust the numerical value of external line.

MAIN MENU	
SYSTEM SETTING →	
CAMERA SETTING →	
FUNCTION SETTING →	
WINDOW BLANKING →	
ALARMS →	
BACK	
EXIT	



CAMERA SETTING	
ZOOM SPEED	HIGH
DIGITAL ZOOM	ON
BLC MODE	OFF
SLOW SHUTTLE	ON
IR CUT FILTER	AUTO
LINE SYNC	101
ADVANCE SETTING →	
BACK	
EXIT	



ADVANCE SETTING	
⚙️ AE MODE > AUTO	
SHUTTER	1/50
IRIS	F1.4
BRIGHT	F2.0/OdB
BW MODE	AUTO
R GAIN	100
B GAIN	100
BACK	
EXIT	

5.7 Advance setting

1. Use 95 preset to enter into the main menu.
2. Operate joystick, move the cursor to [CAMERA SETTING] to enter submenu.
3. Operate joystick, move the cursor to [ADVANCE SETTING]; press [OPEN] to enter submenu, as left picture shows;

5.7.1 AE mode

1. Operate joystick, move the cursor to [AE MODE], press [OPEN], tilt up/down joystick to choose AE mode, modes for choosing as follow:

- **【AUTO】** : default setting, auto Iris mode
- **【BRIGHT】** : brightness priority mode
- **【IRIS】** : iris priority mode
- **【SHUTTER】** : shutter priority mode

2. Choose Iris priority mode [IRIS], press [OPEN] to save.

3. Move joystick to the sub-choices of AE mode [IRIS F1.4], press [OPEN] to choose adequate Iris, press [OPEN] to save.

- **【 SHUTTER 1/50】** it means shutter speed, when AE mode is shutter priority, this function can be set.

- **【 IRIS F1.4】** it means the size of iris, when AE mode is iris priority, this function can be set.

- **【BRIGHT F2.0/OdB】** it means brightness, when AE mode is brightness priority, this function can be set.

Operation knacks



Quality of photo relates to exposure amount, that is to say how much light can make CCD receives legible image. Exposure amount is relative to the time of lighten (be up to shutter speed) and the area of lighten (be up to the size of iris).

The camera can automatically calculate suitable exposure amount according to brightness of scenery and CCD sensitivity, in the situation that the exposure amount is certain: [SHUTTER] (shutter priority) is to fix shutter speed, the camera will auto decide to use how much iris; [IRIS] (iris priority) is to fix the size of iris, and auto-decide to use shutter speed. [BRIGHT] (brightness priority) is that the camera TTL glistens examine directly and control the brightness of image.

MAIN MENU	
SYSTEM SETTING	⇒
CAMERA SETTING	⇒
FUNCTION SETTING	⇒
WINDOW BLANKING	⇒
ALARMS	⇒
BACK	
EXIT	



CAMERA SETTING	
ZOOM SPEED	HIGH
DIGITAL ZOOM	ON
BLC MODE	OFF
SLOW SHUTTLE	ON
IR CUT FILTER	AUTO
LINE SYNC	101
ADVANCE SETTING	⇒
BACK	
EXIT	



ADVANCE SETTING	
AE MODE	AUTO
SHUTTER	1/50
IRIS	F1.4
BRIGHT	F2.0/ODB
⚙️ BW MODE	➤ AUTO
R GAIN	100
B GAIN	100
BACK	
EXIT	

5.7.2 White balance mode

System supports [AUTO], indoor mode [INDOOR], outdoor mode [OUTDOOR], auto track mode [ATW], single mode [OPW], [OPT] mode, manual mode [MANUAL] and kinds of white balance modes, etc.

Detail setting as follow:

1、 Use 95 preset to enter into the main menu; according to the order in left picture to click each command, enter into “ senior setting” menu.

2、 Operate joystick, move the cursor to [BW MODE] to choose white balance mode, press [OPEN] to save.

Auto mode [AUTO] is the default mode of speed dome, which is auto-revert its true color after the sensor of camera runs environmental sense. When choosing manual mode [MANUAL], adjust the numerical value of [R GAIN] and [B GAIN].

- **【R GAIN】 the range is 1-225; the numerical value is bigger, it means that adding red is more, the tone changes to be warm.**
- **【B GAIN】 the range is 1-225; the numerical value is bigger, it means that adding green is more, the tone changes to be cold.**

Indoor mode [INDOOR], and the tone leans to cold.

Outdoor mode [OUTDOOR], and the tone leans to warm.

6. Function setting

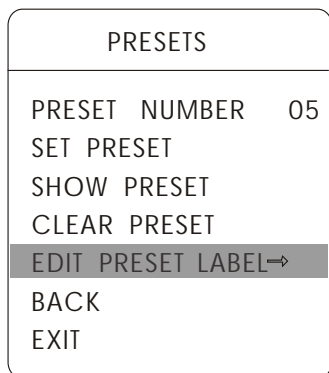
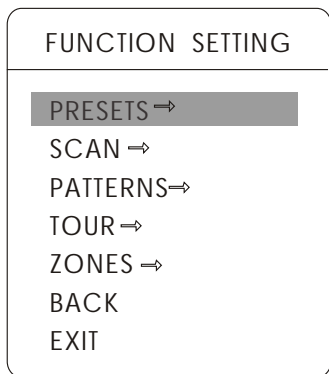
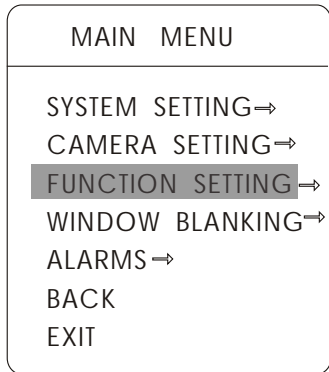

6.1 preset setting

1、 Use 95 preset to enter into the main menu; according to the order of the left picture, to click each command to enter “ preset menu” , various functions as follow:

- **【PRESET NUMBER】 select preset number as current preset**
- **【SET PRESET】**
- **【SHOW PRESET】**
- **【CLEAR PRESET】**
- **【EDIT PRESET LABEL】**

Program preset and display preset function can be set by keyboard operation, input preset number at first, then click the key “ save preset/call preset” to carry out.

2、 Choose current preset number: move the cursor to [PRESET NUMBER], press [OPEN] to choose preset number, the range is 01-80, as the left picture shows, here chooses number 5 as current preset, the following operations aim at the current preset.

3、 Program current preset: move the cursor to [SET PRESET], press [OPEN], by operating joystick to adjust magnification, to choose good objective image, press [OPEN] to save. If the image is nearer, the image is belonging to digital zoom image; when setting preset, the image will jump to maximal optical zoom.



Operation knacks

Preset function is that dome stores current pan/tilt angle, zoom and other position parameters into the memory. When necessary dome recalls these parameters and adjust camera to that position.

4、 Display current preset: move the cursor to [SHOW PRESET], press [OPEN], the screen will display the current preset;

5、 Clear current preset: move the cursor to [CLEAR PRESET], press [OPEN], the current preset is cleared.

6、 Edit current preset label: move the cursor to [EDIT PRESET LABEL], press [OPEN] to enter into editing preset submenu, system auto-sets label as PRESET-XX, press [OPEN] to revise label.



Notice: 1. When running to program, display, clear preset and edit label, should choose preset number at first.

2. The label may set up to 16 characters, and doesn't need editing characters. Pressing [Open] continuously to jump over and using spacebar to replace the deleted characters.

When you finish to edit a character, pressing [Open] to enter into the next editing character; when you finish to edit the last

character, pressing [Open] to save.

Press [Close] to exit.

Character of label is suitable for choosing as follow: 0-9、 A-Z、 :<>-., space.

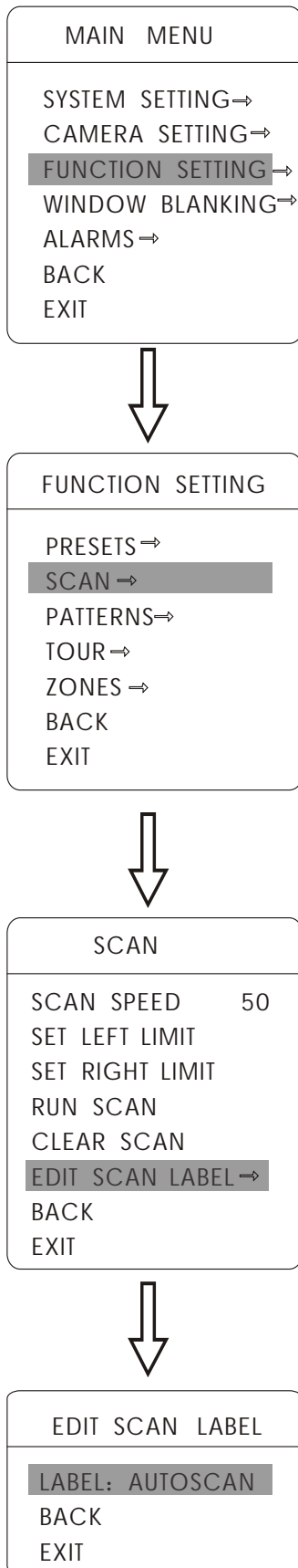

6.2 Scan

Scan is that pre-set two points firstly, then the camera run scan back and forth at a stable speed, the same magnification and pan between the two points. A dome only has a scan tour.

1、 Use 95 preset to enter into the main menu; click menu to enter “ scan” menu, as the left picture shows.

- **【SCAN SPEED】**
- **【SET LEFT LIMIT】**
- **【SET RIGHT LIMIT】**
- **【RUN SCAN】**
- **【CLEAR SCAN】**
- **【EDIT SCAN LABEL】**

2、 Scan speed setting: operate joystick to [SCAN SPEED], press [OPEN], tilt up/down joystick to adjust scan speed, press [OPEN] to save.

3、 Left limit setting: operate joystick to [SET LEFT LIMIT], press [OPEN], operate joystick to choose objective image, press [OPEN] to save.

Right limit setting is the same as left limit setting.

4、 Edit scan label: operate joystick, move the cursor to [EDIT SCAN LABEL], press [OPEN] to enter submenu “ edit label” , move the cursor to [LABEL], the system will auto- set the label as AUTO SCAN, press [OPEN] to revise.

 **Notice:** The label may set up to 16 characters, and doesn't need editing characters. Pressing [Open] continuously to jump over and using spacebar to replace the deleted characters. When you finish to edit a character, pressing [Open] to enter into the next editing character; when you finish to edit the last character, pressing [Open] to save.

Press [Close] to exit.

Character of label is suitable for choosing as follow: 0-9、 A-Z、 :<>-. , space.

The editing ways of other labels are the same.

5、 Run scan: operate joystick to [RUN SCAN], press [OPEN] to exit the menu, and it starts to run scan.

 **Notice:** 1. left limit and right limit of scan can't be set the same point.

2. Under scan process, speed, magnification and tilt direction won't change, if the speed, magnification and tilt direction of the two limits are inconsistent, run scan is subject to left limit.

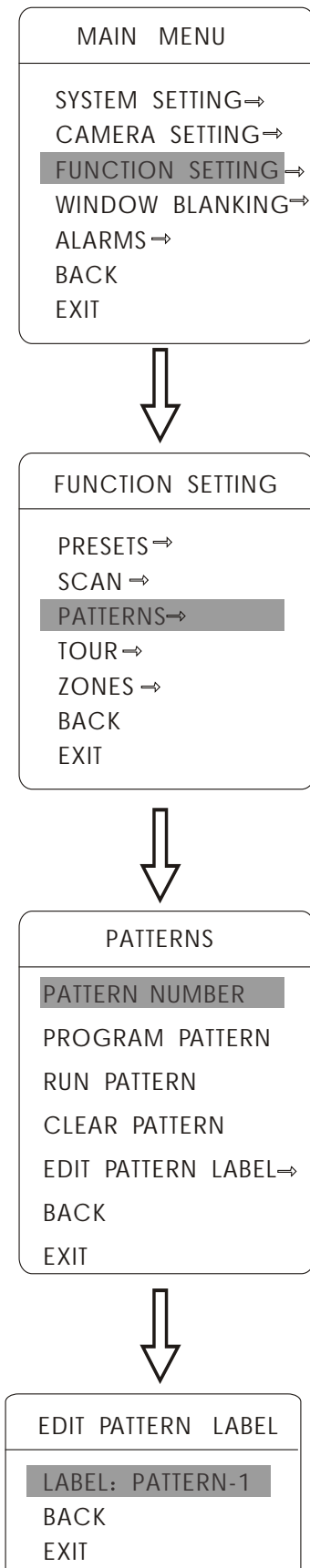

6.3 Pattern

Pattern is built-in function in camera; the speed dome can record tracks that are no less than 180s. (A series of pan/tilt controlling and lens controlling command). A dome may set up to 4 pattern tours.

- 1、 Use 95 preset to enter into the main menu.
- 2、 Operate joystick, move the cursor to [FUNCTION SETTING], press [OPEN] to enter submenu.
- 3、 Operate joystick to [PATTERN], press [OPEN] to enter menu "Pattern" .
 - **【PATTERN NUMBER】 choose current pattern number as the current pattern.**
 - **【PROGRAM PATTERN】 program the track of the current pattern**
 - **【RUN PATTERN】 run current pattern**
 - **【CLEAR PATTERN】 clear current pattern**
 - **【EDIT PATTERN LABEL】 edit current pattern label**
- 4、 Choose pattern number: move the cursor to [PATTERN NUMBER], press [OPEN], pattern you choose as current pattern, the following operations aim at the current pattern;
- 5、 Program current pattern tour: move the cursor to [PROGRAM PATTERN], press [OPEN] to set pattern track, move the image wantonly, and draw the focus. The dome has a tour that is no less than 180s, a series of park time, magnification, focus will be recorded, press [OPEN] to save.
- 6、 Run pattern: Operate joystick to [RUNPATTERN], press [OPEN] to run, the dome will continuously and repeatedly record the specific track.



Notice:

When running to program, run, clear pattern and edit label, should choose pattern number at first.

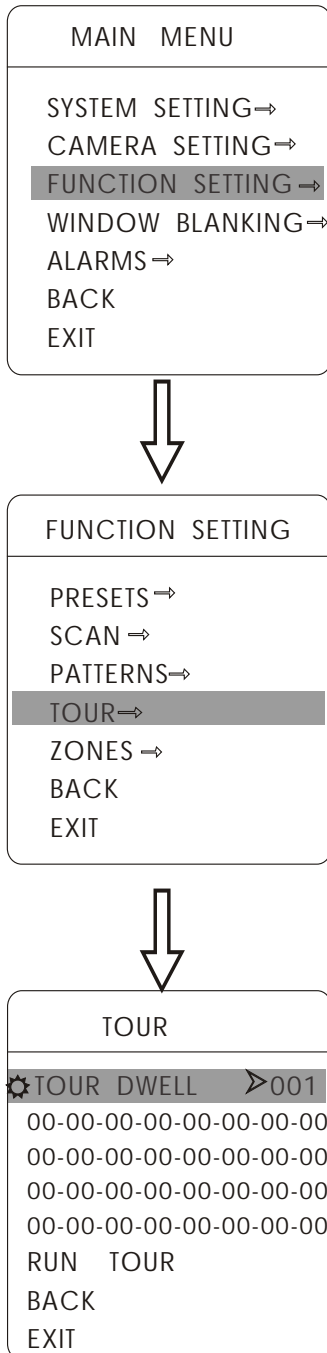

6.4 Tour

Tour is the built-in function in the speed dome, is to make preset arranged in needful order in tour queue by programming in advance. To make camera tour between presets by inserting presets in a tour. It is feasible to program tour order, each time as you run tour, you can set the park time of preset. A tour can store 32 presets.

- 1、 Use 95 preset to enter into the main menu;
- 2、 Operate joystick, move the cursor to [FUNCTION SETTING], press [OPEN] enter submenu.
- 3、 Operate joystick, move the cursor to [TOUR], press [OPEN] to enter menu “tour” ;
- 4、 Set the park time of preset: Operate joystick, move the cursor to [TOUR DWELL], press [OPEN], there will be a sign ⚙️ in the front of [TOUR DWELL], the cursor jumps to right, tilt up/down to set park time, and the range is 000-255(s);
- 5、 Set tour: move the cursor to tour dwell [00-00-00...00], press [OPEN], the first dwell is activated, tilt up/down joystick to choose preset number, press [OPEN], the cursor jumps to the next dwell, press [CLOSE], the cursor jumps to the former dwell. After finishing the last dwell of a line, press [CLOSE] to save. Press [CLOSE] to exit. If set the presets of the second line, move the cursor to the second line, press [OPEN] to edit continuously. When the numerical value is 00, the following presets are invalid.
- 6、 Run tour: Operate joystick, move the cursor to [RUN TOUR], press [OPEN] to exit the menu, it stars to run tour.

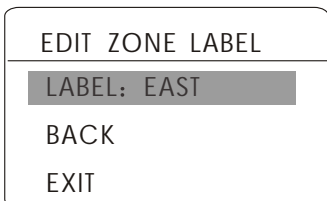
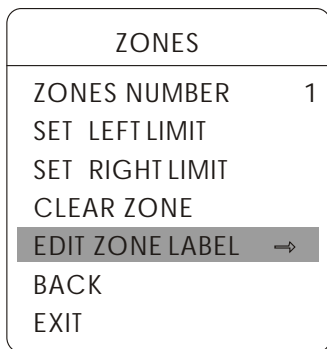
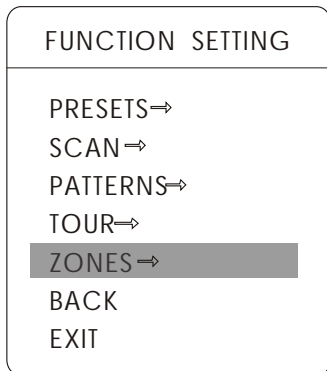
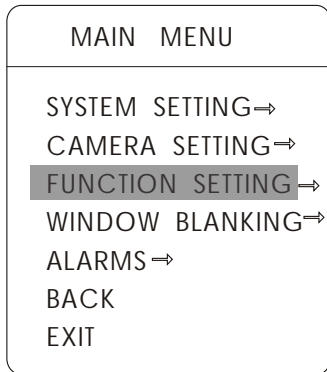

6.5 Zone setting

A dome may be set up to 8 zones; the regional scene can't be overlapped. User will set label for each zone. When setting [ZONE LABEL] as ON, the dome will display zone label as it runs some zone. It is convenient to know the zone that the camera shoots by setting zone label.

1. Use 95 preset to enter into the main menu.
2. Operate joystick, move the cursor to [FUNCTION SETTING], press [OPEN] to enter submenu.
3. Operate joystick, move the cursor to [ZONES], press [OPEN] to enter submenu, as the left picture shows.

- **【ZONES NUMBER】** choose zone number as current zone, there choices in the menu aim at current zone.
- **【SET LEFT LIMIT】** set current zone's left limit
- **【SET RIGHT LIMIT】** set current zone's right limit
- **【CLEAR ZONE】** clear current zone setting
- **【EDIT ZONE LABEL】** edit current zone label, as zone number is 1. Zone label will auto-change as ZONE-1

Regard the left/right limit as the demarcation line, and set the middle part as a zone. Various operational ways are the same as other settings in the menu. Therefore we won't explain it again.

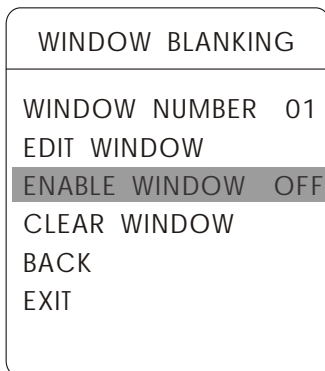
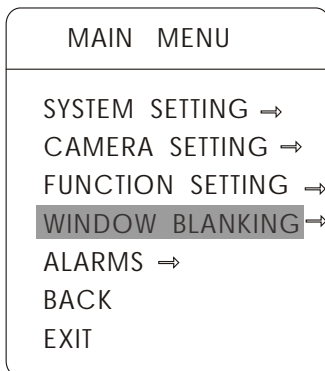

7. Privacy zone masking

Privacy function can show some one piece of regional shielding while protecting. For example, protect the window of bedroom or ATM of bank. A dome may set to 24 privacy windows.

1、 Use 95 preset to enter into the main menu.

2、 Operate joystick to [WINDOW BLANKING], press [OPEN] to enter menu “ window blanking” .

- **【WINDOW NUMBER】 choose window number as current privacy window, other choices in the menu just aim at current privacy window;**

- **【EDIT WINDOWS】 program current window;**

- **【ENABLE WINDOWS】 permit/prohibit current privacy window, there are two choice: ON---permit current privacy window/OFF---prohibit current privacy window**

- **【CLEAR WINDOW】 clear current privacy window, after clearing it, the window will auto-change as OFF.**

3、 Program current privacy window: Firstly choose window number, then do the following operations:

a. Operate joystick, move the cursor to [EDIT WINDOW], press [OPEN] to move the image that need privacy window to display in the screen.

b. Press [OPEN], there will be a square displaying in the centre of the screen, operate joystick, and move the square to the central place that need to conceal.

c. Press [OPEN], operate joystick to adjust the size of privacy zone: joystick to up, the height is increased; joystick to down, the height is reduced; joystick to right, the width is increased; joystick to left, the width is reduced.

d. Press [OPEN] to save the current privacy zone setting, and the window will auto-change as ON at the same time.



Notice: When the dome is running scan and tour, privacy window may be a little difference with the setting place. Suggest you to run scan and cruise as setting privacy window, try best to make the same focus for the objective zone and scan/cruise. To do so, the privacy zone hardly has deviation, and plays a protection in the privacy.

Privacy zone masking →



8. Alarm function

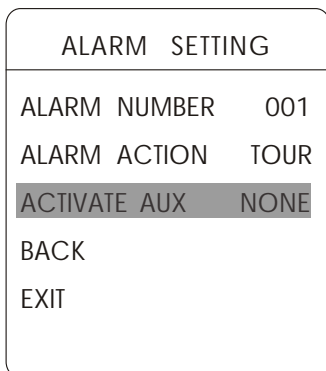
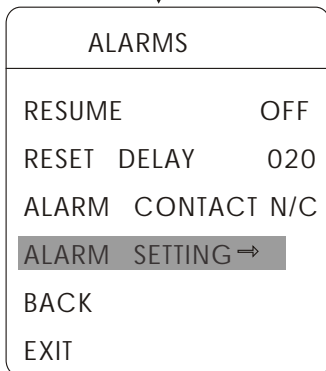
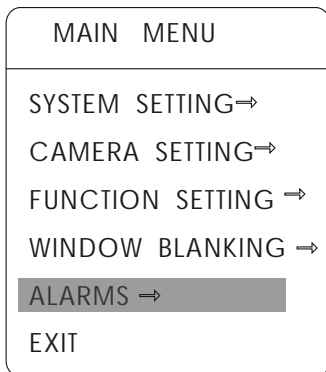

Speed dome may connect with 7 alarm input, 2 alarm output, and support alarm linkage. The external alarm message sends to the dome, then the dome sends to alarm point shoot (to call preset, auto scan, auto cruise and auto pattern), and choose that to run alarm output or not.

1、 Use 95 preset to enter in the main menu, click each menu according to the left picture, then enter menu alarm, choices as follow:

- **【RESUME】 resume mode after relieving alarm input, there are two choices: ON---clear alarm output, the dome will stop. /OFF---just clear alarm output.**
- **【RESET DELAY】** set alarm reset and delay the time (1-225s), how long to relieve and run [RESUME] after the dome receives alarm message.
- **【ALARM CONTACT】** set state of the relay. N/C---often close the state, N/O---often hold the state. If setting as often closing the state, the relay is in closing the state when there is no alarm to output; when there is alarm to output, the relay is in holding the state.
- **【ALARM SETTING】**

2、 Move joystick to [ALARM SETTING], press [OPEN] to enter the menu alarm setting

- **【ALARM NUMBER】** alarm number is corresponding with 12 bits plug in the external switching board of the dome(as below shows). 001 priority is the highest, 007 priority is the lowest. The two lines alarm input at the same time, the dome run alarm that the highest priority.
- **【ALARM ACTION】** as current alarm input, to run the action. Choices for choosing as follow. NONE---none action/SCAN/PAT X---run a pattern tour/TOUR---run tour/PRESET---call preset, when the dome number is set as 1, to call preset 1; when the dome number is set as 2, to call preset 2.
- **【ACTIVATE AUX】** as current alarm input, to run alarm output or not. NONE---none alarm output/AUX 1---the first alarm output/AUX 2---the second alarm output/BOTH--- two alarms output.

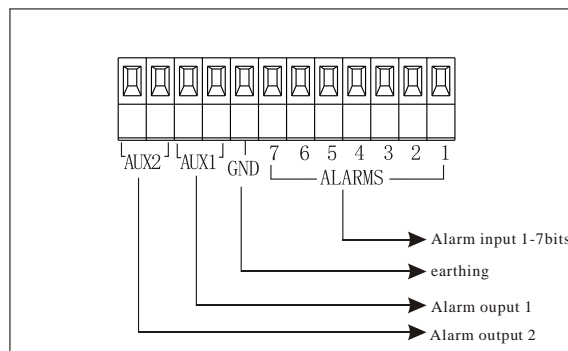

9.2 Troubleshooting

Trouble	Possible causes	Solution
No action , no Video after power up	<ol style="list-style-type: none"> 1.The 24vAC power supply is Not connected to the port of the Circuit connection board or the contact is not good. 2、 The municipal power has been cut off or the transformer is in malfunction. 	<ol style="list-style-type: none"> 1.Check the power supply to see if it is connected or confirm if the plug contact well. 2.Check to see of the municipal power supply has been cut off. Check to see if the 24Vac transformer is OK.
Self-testing and image Are normal but the dome is uncontrollable	<ol style="list-style-type: none"> 1.The dome Dipswitchsetting is incorrect. 2.RS485 may carve out a way 3.RS485 is in malfunction. 	<ol style="list-style-type: none"> 1. Reset the Dipswitch as per the Dipswitch setting chart. 2. Check RS485 and confirm the connection is correct and good in contact. 3. Please consult appendix 3.1 RS485 is in Malfunction.
Fan does not function	<ol style="list-style-type: none"> 1.Wire connection of fan is not good 2.The environmental temp is -10°C . 	<ol style="list-style-type: none"> 1.Connect the fan wire, if the fan still does not function, please contact the distributor or factor 2.Make the dome work in feasible temp.
Vague image	<ol style="list-style-type: none"> 1.Manual focus has been set. 2.Unclean down cover. 	<ol style="list-style-type: none"> 1.Operate dome and set the state of focus as auto or call any preset. 2.Clean the down cover.

9.3 The cleaning of clear down cover

To obtain constant clear videos, user should clean the down cover periodically.

- Be caution when cleaning, Hold the down cover ring only to avoid direct touch to the acrylic down cover. The acid sweat mark of fingerprint will corrode the coating of down cover and scratch on down cover will cause vague image.
- Use soft dry cloth or the substitute to clean the inner and outer surfaces.
- For hard contamination, use neutral detergent. Any cleanser for high grade furniture is applicable.

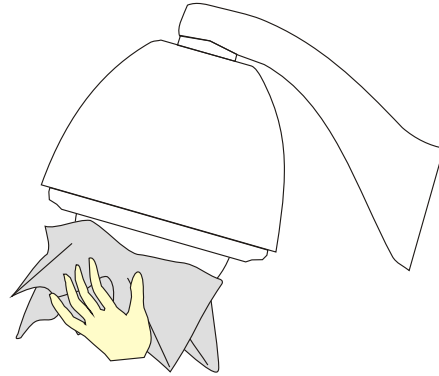

9.4 Rs485 Bus Basic Knowledge

➤ Characteristics of Rs485 Bus

As specified by Rs485 standard, Rs485 Bus is of half-duplexed data transmission cables with characteristic impedance as 120Ω . The maximum load capacity is 32 unit loads (including main controller and controlled equipment.)

➤ Transmission distances of Rs485 Bus

When user selects the 0.56mm(24AWG)twisted pair wires as data transmission cable, the maximum theoretical transmitting distance are as follows:

Baud rate	Max distance
2400BPS	1800m
4800BPS	1200m
9600BPS	800m
19200BPS	600m

If user selects thinner cables, or installs the dome in an environment with strong electromagnetic interference, or connects lots of equipment to the Rs485 Bus, the maximum transmitting distance will be decreased. To increase the maximum transmitting distance, do the contrary.

➤ Connection and termination resistor

The Rs485 standards require a daisy-chain Connection between the equipment. There must be termination resistors with 120Ω (as the picture9-4.1). Please refer to picture 9-4.2 for simple connection. “D” should not exceed 7m.

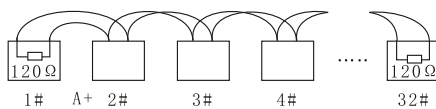

Picture9-4.1

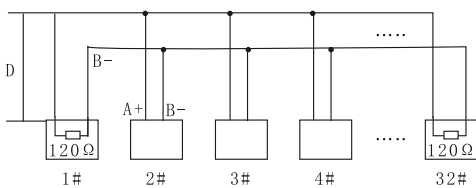

Picture9-4.2

➤ The connection of 120Ω termination resistor:

The termination resistor is ready on the protocol PCB.

There are two kinds of connection (as shown in 9-4.3 form). It is the factory default connection. The jumper cap of switchboard is seated on pin 2 & pin 3 and the termination resistor 120Ω is not connected.

When connecting the 120Ω termination resistor, user should pull out the protocol PCB and plug the jumper on pin 1 & pin 2. Install the PCB back and the termination resistor is connected. (as shown in the picture 9-4.3)

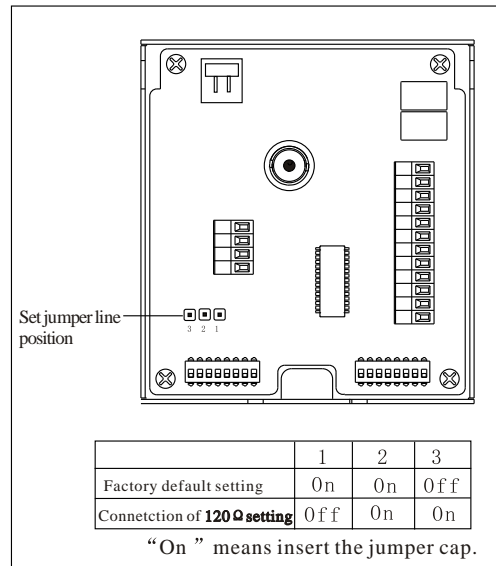

Picture9-4.3

➤ **Problems in practical connections**

In some circumstances user adopts a star configuration in practical connection. The termination resistors must be connected to the two equipment 1# and 5# in Picture 9-4.4. As the star configuration is not in conformity with the requirements of RS485 standards, problems such as signal reflections, lower anti-interference performance arise when the cables are long in the connection. The reliability of control signals is decreased with the phenomena that the dome does not respond to or just responds at intervals to the controller, or does continuous operation without stop.

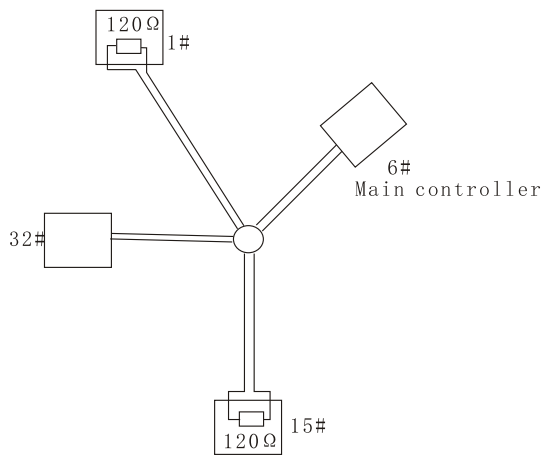

Picture9-4.4

In such circumstances the factory recommends the usage of RS485 distributor. The distributor can change the star configuration connection to the mode of connection stipulated in the RS485 standards. The new connection achieves reliable data transmission. (refer to Picture 9-4.5).

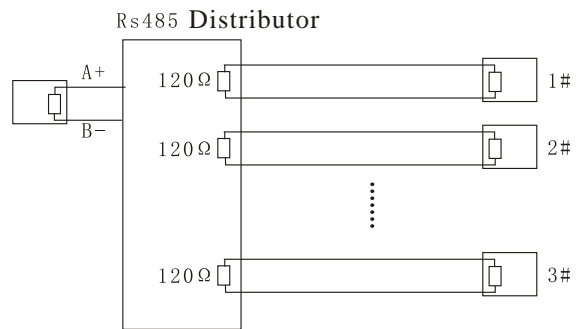

Picture9-4.5

➤ **Rs485 Bus troubleshooting**

Trouble	Possible cause	Solution
Dome can do self-testing but cannot be controlled	A、 The address and baud rate setting of dome are not in conformity with those of controller. B、 The "+" and "-" connection of Rs485 Bus is incorrect. C、 The dome is very far away from controller. D、 There are too many domes connected in the System.	A、 Change the address and baud rate of controller or dome B、 Replace Rs485 Bus wires C、 Make sure the connections are fully seated
The dome can be controlled but the operation is not smooth.	A、 The Rs485 Busline is not in good contact with the connectors. B、 One wire of the Rs485 Bus is broken. C、 The dome is very far from controller. D、 There are too many domes connected in the system.	A、 Secure the connection; B、 Replace Rs485 Bus Wires C、 Add termination resistors to the system D、 Install Rs485 distributor

9.5 DIPswitch setup

There is a switchboard in the upper cover of dome, lift the metallic button can open the switchboard. There are two 8-bit DIP switches on it. Sw2 is for protocol and baud rate setting and Sw1 is for dome address setting.

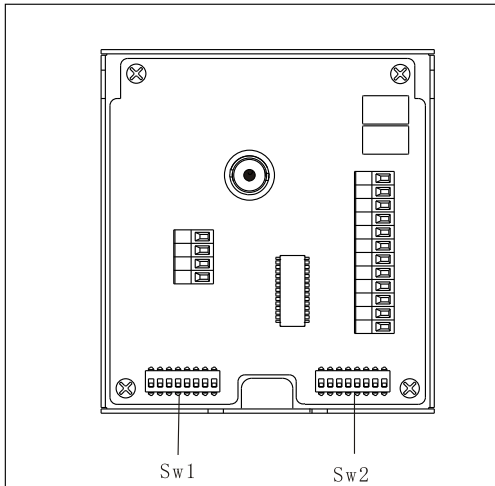

Picture9-5.1

In the following list, "1" set DIP as "ON" 0 set DIP as "OFF"

9.5.1 Baud rate setup (SW2) :

Please according to "3.1Rs485 Bus Basic knowledge", to check whether Baud rate is satisfied with the demand of transmission distance.

Baud rate	Switch (Sw2)	
	(Bit) 7	8
2400bps	0	0
4800bps	1	0
9600bps	0	1
19200bps	1	1

9.5.2 Protocolsetup (SW2)

Protocol	Switch number (Sw2)					
	(Bit) 1	2	3	4	5	6
FACTORY (factory protocol)	0	0	0	0	0	0
PELCO	1	0	0	0	0	0
SAE	0	1	0	0	0	0
VCL	1	1	0	0	0	0
MOLYNX	0	0	1	0	0	0
VICON	1	0	1	0	0	0
SANTACHI	0	1	1	0	0	0
PANASONIC	1	1	1	0	0	0
SAMSUNG	0	0	0	1	0	0
DIAMOND	1	0	0	1	0	0
KALATEL	0	1	0	1	0	0
LILIN	1	1	0	1	0	0
ADT SECUPRO	0	0	1	1	0	0
HUNDA	1	0	1	1	0	0
PHILIPS	0	0	0	0	0	1
AD	1	0	0	0	0	1
UNIVISION	0	1	0	0	0	1
Reserved	OTHERS					

9.5.3 IDsetting (SW1)

In a system, a decoder includes speed dome camera and common decoder, there aren't the same ID between them. The ID switch in decoder and the ID setting of the dome as follow, in the picture, "1" set DIP switch as "NO", "0" set DIP switch as OFF.

ID	Switch number (Sw1)								ID	Switch number (Sw1)							
	(Bit)1	2	3	4	5	6	7	8		(Bit)1	2	3	4	5	6	7	8
0 factory protocol as debug address	0	0	0	0	0	0	0	0	34	0	1	0	0	0	1	0	0
1	1	0	0	0	0	0	0	0	35	1	1	0	0	0	1	0	0
2	0	1	0	0	0	0	0	0	36	0	0	1	0	0	1	0	0
3	1	1	0	0	0	0	0	0	37	1	0	1	0	0	1	0	0
4	0	0	1	0	0	0	0	0	38	0	1	1	0	0	1	0	0
5	1	0	1	0	0	0	0	0	39	1	1	1	0	0	1	0	0
6	0	1	1	0	0	0	0	0	40	0	0	0	1	0	1	0	0
7	1	1	1	0	0	0	0	0	41	1	0	0	1	0	1	0	0
8	0	0	0	1	0	0	0	0	42	0	1	0	1	0	1	0	0
9	1	0	0	1	0	0	0	0	43	1	1	0	1	0	1	0	0
10	0	1	0	1	0	0	0	0	44	0	0	1	1	0	1	0	0
11	1	1	0	1	0	0	0	0	45	1	0	1	1	0	1	0	0
12	0	0	1	1	0	0	0	0	46	0	1	1	1	0	1	0	0
13	1	0	1	1	0	0	0	0	47	1	1	1	1	0	1	0	0
14	0	1	1	1	0	0	0	0	48	0	0	0	0	1	1	0	0
15	1	1	1	1	0	0	0	0	49	1	0	0	0	1	1	0	0
16	0	0	0	0	1	0	0	0	50	0	1	0	0	1	1	0	0
17	1	0	0	0	1	0	0	0	51	1	1	0	0	1	1	0	0
18	0	1	0	0	1	0	0	0	52	0	0	1	0	1	1	0	0
19	1	1	0	0	1	0	0	0	53	1	0	1	0	1	1	0	0
20	0	0	1	0	1	0	0	0	54	0	1	1	0	1	1	0	0
21	1	0	1	0	1	0	0	0	55	1	1	1	0	1	1	0	0
22	0	1	1	0	1	0	0	0	56	0	0	0	1	1	1	0	0
23	1	1	1	0	1	0	0	0	57	1	0	0	1	1	1	0	0
24	0	0	0	1	1	0	0	0	58	0	1	0	1	1	1	0	0
25	1	0	0	1	1	0	0	0	59	1	1	0	1	1	1	0	0
26	0	1	0	1	1	0	0	0	60	0	0	1	1	1	1	0	0
27	1	1	0	1	1	0	0	0	61	1	0	1	1	1	1	0	0
28	0	0	1	1	1	0	0	0	62	0	1	1	1	1	1	0	0
29	1	0	1	1	1	0	0	0	63	1	1	1	1	1	1	0	0
30	0	1	1	1	1	0	0	0	64	0	0	0	0	0	0	1	0
31	1	1	1	1	1	0	0	0	65	1	0	0	0	0	0	1	0
32	0	0	0	0	0	1	0	0	66	0	1	0	0	0	0	1	0
33	1	0	0	0	0	1	0	0	67	1	1	0	0	0	0	1	0

ID	Switch number (Swl)							
	(Bit)	1	2	3	4	5	6	7
68	0	0	1	0	0	0	1	0
69	1	0	1	0	0	0	1	0
70	0	1	1	0	0	0	1	0
71	1	1	1	0	0	0	1	0
72	0	0	0	1	0	0	1	0
73	1	0	0	1	0	0	1	0
74	0	1	0	1	0	0	1	0
75	1	1	0	1	0	0	1	0
76	0	0	1	1	0	0	1	0
77	1	0	1	1	0	0	1	0
78	0	1	1	1	0	0	1	0
79	1	1	1	1	0	0	1	0
80	0	0	0	0	1	0	1	0
81	1	0	0	0	1	0	1	0
82	0	1	0	0	1	0	1	0
83	1	1	0	0	1	0	1	0
84	0	0	1	0	1	0	1	0
85	1	0	1	0	1	0	1	0
86	0	1	1	0	1	0	1	0
87	1	1	1	0	1	0	1	0
88	0	0	0	1	1	0	1	0
89	1	0	0	1	1	0	1	0
90	0	1	0	1	1	0	1	0
91	1	1	0	1	1	0	1	0
92	0	0	1	1	1	0	1	0
93	1	0	1	1	1	0	1	0
94	0	1	1	1	1	0	1	0
95	1	1	1	1	1	0	1	0
96	0	0	0	0	0	1	1	0
97	1	0	0	0	0	1	1	0
98	0	1	0	0	0	1	1	0
99	1	1	0	0	0	1	1	0
100	0	0	1	0	0	1	1	0
101	1	0	1	0	0	1	1	0
102	0	1	1	0	0	1	1	0
103	1	1	1	0	0	1	1	0
104	0	0	0	1	0	1	1	0
105	1	0	0	1	0	1	1	0
106	0	1	0	1	0	1	1	0
107	1	1	0	1	0	1	1	0
108	0	0	1	1	0	1	1	0
109	1	0	1	1	0	1	1	0
110	0	1	1	1	0	1	1	0
111	1	1	1	1	0	1	1	0
112	0	0	0	0	1	1	1	0
113	1	0	0	0	1	1	1	0
114	0	1	0	0	1	1	1	0
115	1	1	0	0	1	1	1	0
116	0	0	1	0	1	1	1	0
117	1	0	1	0	1	1	1	0
118	0	1	1	0	1	1	1	0
119	1	1	1	0	1	1	1	0
120	0	0	0	1	1	1	1	0
121	1	0	0	1	1	1	1	0
122	0	1	0	1	1	1	1	0
123	1	1	0	1	1	1	1	0
124	0	0	1	1	1	1	1	0
125	1	0	1	1	1	1	1	0
126	0	1	1	1	1	1	1	0
127	1	1	1	1	1	1	1	0
128	0	0	0	0	0	0	0	1
129	1	0	0	0	0	0	0	1
130	0	1	0	0	0	0	0	1
131	1	1	0	0	0	0	0	1
132	0	0	1	0	0	0	0	1
133	1	0	1	0	0	0	0	1
134	0	1	1	0	0	0	0	1
135	1	1	1	0	0	0	0	1

ID	Switch number (Swl)								ID	Switch number (Swl)							
	(Bit)	1	2	3	4	5	6	7		8	(Bit)	1	2	3	4	5	6
136	0	0	0	1	0	0	0	1	170	0	1	0	1	0	1	0	1
137	1	0	0	1	0	0	0	1	171	1	1	0	1	0	1	0	1
138	0	1	0	1	0	0	0	1	172	0	0	1	1	0	1	0	1
139	1	1	0	1	0	0	0	1	173	1	0	1	1	0	1	0	1
140	0	0	1	1	0	0	0	1	174	0	1	1	1	0	1	0	1
141	1	0	1	1	0	0	0	1	175	1	1	1	1	0	1	0	1
142	0	1	1	1	0	0	0	1	176	0	0	0	0	1	1	0	1
143	1	1	1	1	0	0	0	1	177	1	0	0	0	1	1	0	1
144	0	0	0	0	1	0	0	1	178	0	1	0	0	1	1	0	1
145	1	0	0	0	1	0	0	1	179	1	1	0	0	1	1	0	1
146	0	1	0	0	1	0	0	1	180	0	0	1	0	1	1	0	1
147	1	1	0	0	1	0	0	1	181	1	0	1	0	1	1	0	1
148	0	0	1	0	1	0	0	1	182	0	1	1	0	1	1	0	1
149	1	0	1	0	1	0	0	1	183	1	1	1	0	1	1	0	1
150	0	1	1	0	1	0	0	1	184	0	0	0	1	1	1	0	1
151	1	1	1	0	1	0	0	1	185	1	0	0	1	1	1	0	1
152	0	0	0	1	1	0	0	1	186	0	1	0	1	1	1	0	1
153	1	0	0	1	1	0	0	1	187	1	1	0	1	1	1	0	1
154	0	1	0	1	1	0	0	1	188	0	0	1	1	1	1	0	1
155	1	1	0	1	1	0	0	1	189	1	0	1	1	1	1	0	1
156	0	0	1	1	1	0	0	1	190	0	1	1	1	1	1	0	1
157	1	0	1	1	1	0	0	1	191	1	1	1	1	1	1	0	1
158	0	1	1	1	1	0	0	1	192	0	0	0	0	0	0	1	1
159	1	1	1	1	1	0	0	1	193	1	0	0	0	0	0	1	1
160	0	0	0	0	0	1	0	1	194	0	1	0	0	0	0	1	1
161	1	0	0	0	0	1	0	1	195	1	1	0	0	0	0	1	1
162	0	1	0	0	0	1	0	1	196	0	0	1	0	0	0	1	1
163	1	1	0	0	0	1	0	1	197	1	0	1	0	0	0	1	1
164	0	0	1	0	0	1	0	1	198	0	1	1	0	0	0	1	1
165	1	0	1	0	0	1	0	1	199	1	1	1	0	0	0	1	1
166	0	1	1	0	0	1	0	1	200	0	0	0	1	0	0	1	1
167	1	1	1	0	0	1	0	1	201	1	0	0	1	0	0	1	1
168	0	0	0	1	0	1	0	1	202	0	1	0	1	0	0	1	1
169	1	0	0	1	0	1	0	1	203	1	1	0	1	0	0	1	1

ID	Switch number (Sw1)							
	(Bit)1	2	3	4	5	6	7	8
204	0	0	1	1	0	0	1	1
205	1	0	1	1	0	0	1	1
206	0	1	1	1	0	0	1	1
207	1	1	1	1	0	0	1	1
208	0	0	0	0	1	0	1	1
209	1	0	0	0	1	0	1	1
210	0	1	0	0	1	0	1	1
211	1	1	0	0	1	0	1	1
212	0	0	1	0	1	0	1	1
213	1	0	1	0	1	0	1	1
214	0	1	1	0	1	0	1	1
215	1	1	1	0	1	0	1	1
216	0	0	0	1	1	0	1	1
217	1	0	0	1	1	0	1	1
218	0	1	0	1	1	0	1	1
219	1	1	0	1	1	0	1	1
220	0	0	1	1	1	0	1	1
221	1	0	1	1	1	0	1	1
222	0	1	1	1	1	0	1	1
223	1	1	1	1	1	0	1	1
224	0	0	0	0	0	1	1	1
225	1	0	0	0	0	1	1	1
226	0	1	0	0	0	1	1	1
227	1	1	0	0	0	1	1	1
228	0	0	1	0	0	1	1	1
229	1	0	1	0	0	1	1	1
230	0	1	1	0	0	1	1	1
231	1	1	1	0	0	1	1	1
232	0	0	0	1	0	1	1	1
233	1	0	0	1	0	1	1	1
234	0	1	0	1	0	1	1	1
235	1	1	0	1	0	1	1	1
236	0	0	1	1	0	1	1	1
237	1	0	1	1	0	1	1	1

ID	Switch number (Sw1)							
	(Bit)1	2	3	4	5	6	7	8
238	0	1	1	1	0	1	1	1
239	1	1	1	1	0	1	1	1
240	0	0	0	0	1	1	1	1
241	1	0	0	0	1	1	1	1
242	0	1	0	0	1	1	1	1
243	1	1	0	0	1	1	1	1
244	0	0	1	0	1	1	1	1
245	1	0	1	0	1	1	1	1
246	0	1	1	0	1	1	1	1
247	1	1	1	0	1	1	1	1
248	0	0	0	1	1	1	1	1
249	1	0	0	1	1	1	1	1
250	0	1	0	1	1	1	1	1
251	1	1	0	1	1	1	1	1
252	0	0	1	1	1	1	1	1
253	1	0	1	1	1	1	1	1
254	0	1	1	1	1	1	1	1
255	1	1	1	1	1	1	1	1



Notice: 1. Debug address: (Only can be set by factory protocol and PELCO): if the camera address is set as 0, use may select any protocols to control the dome.

2. Broadcast address(Only can be set by factory protocol and PELCO): if user selects “255” to control, all the systematic connection cameras will carry our the same motions.

241-8010-EN00-A